

CASH[®] Special & CASH[®] Special Concussion

Original Instruction Manual



©2017 Accles & Shelvoke Ltd



DO NOT ATTEMPT TO USE THESE STUNNING TOOLS UNTIL YOU HAVE READ AND UNDERSTOOD THE USER MANUAL

SECTION	DESCRIPTION	PAGES
	CONTENTS	2
1	PRODUCT DESCRIPTION	3
2	PRODUCT SPECIFICATION	4
3	PRODUCT DIAGRAM	5
4	ANIMAL WELFARE	6
5	EFFECTIVE STUNNING & CARTRIDGE SELECTION	7
6	GENERAL SAFETY PRECAUTIONS	15
7	SAFE OPERATING INSTRUCTIONS	17
8	CLEANING AND GENERAL MAINTENANCE	19
9	TROUBLESHOOTING	24
10	SERVICING	26
11	SPARE PARTS LIST AND DIAGRAM	32
12	DISPATCH KIT	35
13	CONTACT DETAILS, WARRANTY AND RECYCLING	39
	DECLARATION OF CONFORMITY CERTIFICATE	40

DISCLAIMER

This instruction manual is correct at the time of printing. However, because our policy is one of constant development and improvement, details and images may vary slightly from those provided in this publication.

© Copyright of Accles & Shelvoke Ltd 2017 - All rights reserved

Accles & Shelvoke”, “CASH”, “CASH Special” and “CASH Special Concussion” are all trademarks of Accles & Shelvoke Ltd

ONLY EVER USE GENUINE ACCLES & SHELVOKE REPLACEMENT PARTS. NOT USING GENUINE PARTS MAY LEAD TO PREMATURE COMPONENT AND TOOL FAILURE, WHICH COULD ENDANGER THE OPERATOR AND THOSE IN THE IMMEDIATE VICINITY. IT WILL ALSO INVALIDATE OUR ORIGINAL EQUIPMENT WARRANTY.

ACCLES & SHELVOKE WILL ACCEPT NO LIABILITY IF ANY COMPONENTS OTHER THAN THOSE SUPPLIED BY ACCLES & SHELVOKE ARE USED WITH OUR ORIGINAL EQUIPMENT. THE RESULTANT LIABILITY WILL BE WITH THE END USER OR THE DISTRIBUTOR WHO SUPPLIED THE UNAPPROVED REPLACEMENT PARTS.

The CASH Special range of stunners are cartridge powered, trigger operated, conventional pistol style tools with automatic bolt return. They are available in both penetrative (CASH Special) and concussive (CASH Special Concussion) forms - refer to the table below for the full range. They are available in standard and heavy duty variants, in both .22" and .25" calibre and can be used on a range of animals from poultry to large bulls. CASH Special Concussion tools are suitable for religious slaughter. These tools are intended for professional use.

PRODUCT	PRODUCT CODE	PRODUCT DESCRIPTION	CALIBRE	MAXIMUM PERMITTED CARTRIDGE
CASH Special	4100R	CASH Special .22R	0.22R	3 GRAIN (.22 GREEN)
	4000	CASH Special .22 HD	0.22	4 GRAIN (.22 RED)
	4121	CASH Special .25	0.25	2 GRAIN (.25 YELLOW)
	4121K	CASH Dispatch Kit	0.25R	Refer to Section 12
	4121R	CASH Special .25R	0.25R	3 GRAIN (.25 BLUE)
	4121HD	CASH Special .25R HD	0.25R	3.5 GRAIN (.25 ORANGE)
	4121HL	CASH Special .25R HL	0.25R	3.5 GRAIN (.25 ORANGE)
CASH Special Concussion	4002	CASH Special .22 Concussion	0.22R	2.5 GRAIN (.22 PURPLE)
	4122	CASH Special .25 Concussion	0.25R	2 GRAIN (.25 YELLOW)

The CASH Special range of stunning tools are captive bolt devices which cause severe and irreversible damage to the brain. These tools are designed to stun all designated animals prior to slaughter or depopulation in accordance with EU Council Regulation (EC) number 1099/2009 On the Protection of Animals at the Time of Killing.

EU only - concussion tools shall only be used for ruminants of less than 10kg of live weight.

The CASH Special range of stunners feature a 'rolling block' firing mechanism which requires two positive actions to operate the tool and features automatic bolt return.

The CASH Special range of stunners have been on the market for many years, and in that time have earned a reputation for being a reliable and effective tool, operating on lines processing up to 450 animals per hour (if maintained according to our guidelines and when used with two or more tools as part of a planned alternating operating routine).

To ensure the safety of the operator, and quality of products, all Accles & Shelvoke stunning tools are proof tested in accordance with the Rules of Proof 2006. We have several 'assistant proof masters' who are accredited by the British Proof House (formerly the Birmingham Proof House, www.gunproof.com). We work to standards set by the Commission Internationale Permanente pour l'Epreuve des Armes à Feu Portatives (CIP). All stunning tools are "Proofed" prior to the stunners being released to customers. Proofed components are stamped with the mark of the British Proof House (image below), so that users can be assured of the quality and safety of the product.

ATTRIBUTE	STUNNER MODEL NUMBER								
	4100R	4000	4121	4121K	4121R	4121HD	4121HL	4002	4122
Length (mm)	270	270	270	258 to 295	270	275	295	285	285
Height (mm)	190	190	190	190	190	190	190	190	190
Width (mm)	50	50	50	50	50	50	50	50	50
Weight (kg) *	2.8	2.8	2.8	2.8 to 3.0	2.8	2.9	3.0	3.0	3.0
'A' weighted Sound Pressure Level at workstation (dB)	82	82	83	83	83	83	83	82	83
'A' weighted Sound Power Level (dB)	87	87	89	89	89	89	89	87	89
'C' weighted Peak emissions (dB)	119	119	119	119	119	119	119	119	119
Calibre	.22R	0.22	0.25	.25R	.25R	.25R	.25R	.22R	.25R
Chamber	Reduced	Straight	Straight	Reduced	Reduced	Reduced	Reduced	Reduced	Reduced
Bolt length	Standard	Standard	Standard	Short, medium and long	Standard	Medium	Long	Concussion Only	Concussion Only
Action (sear rod and hammer arrangement)	Standard	Heavy duty	Standard	Heavy duty	Heavy duty	Heavy duty	Heavy duty	Standard	Heavy duty

* Rounded to 1 decimal place.

Sound values determined according to EN 15895 using EN ISO 3744, using the maximum rated cartridge for a given tool. Tests conducted using simulated load (paper sheets and plasticine).

The A-weighted sound pressure level and A-weighted sound power level have been calculated - and are hence valid - at the maximum number of driving processes in one second.

The maximum number of driving processes in one second for CASH Special tools is one per second. This applies to all of the tools in the range included in this instruction manual.

Information about vibrations

EN 15895 states - for cartridge operated hand tools, the vibration total value to which the hand-arm system is subjected does not exceed 2.5m/s². The generated mechanical recoil that is transmitted into the hand and arm of the operator is not considered to be a vibration.

By analogy, the same applies to the CASH Special product range.

CASH SPECIAL

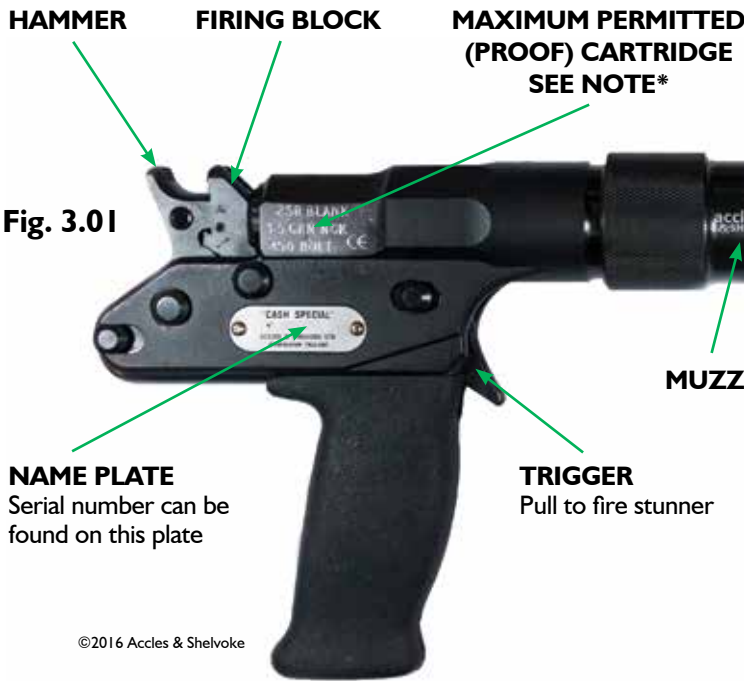

DANGER ZONE!

Assuming recuperator sleeves and washers have been mistakenly omitted from the tool

127mm (5'')

POLEAXE END (OF BOLT)
 Re-sharpen by re-coning using a countersink tool



DO NOT GRIND THE OUTSIDE DIAMETER!

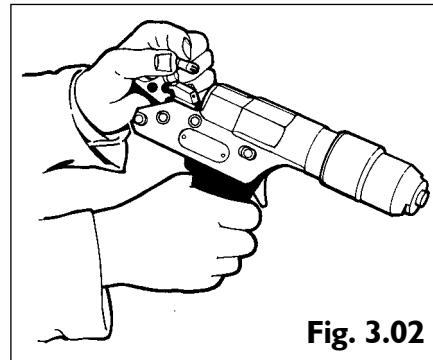
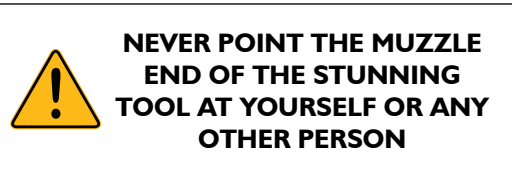
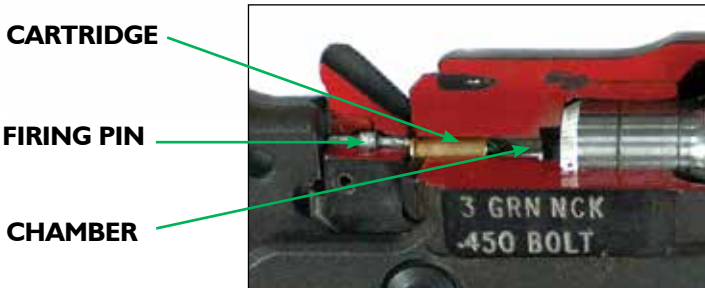

Fig. 3.02

CUT-AWAY VIEW Fig. 3.03



CASH SPECIAL CONCUSSION



DANGER ZONE!

Assuming recuperator sleeves and washers have been mistakenly omitted from the tool

83mm (3 1/4'')

* **NOTE** - Every tool in the CASH Special range is stamped with the maximum permitted (PROOF) cartridge, showing the maximum grains (GRN) that should be used.



NEVER USE A MORE POWERFUL CARTRIDGE THAN THE MAXIMUM PERMITTED CARTRIDGE AS STAMPED ON YOUR STUNNING TOOL

©2016 Accles & Shelvoke

©2016 Accles & Shelvoke

©2016 Accles & Shelvoke

©2016 Accles & Shelvoke

Improving the protection of animals at the time of slaughter contributes to higher meat quality.

EU Only - in accordance with EU Council Regulation (EC) Number 1099/2009 on the protection of animals at the time of killing, animals must be spared any avoidable pain, distress or suffering during their killing and related operations.

Business operators shall in particular take the necessary measures to ensure that animals:

- ▶ Are provided with physical comfort and protection, in particular by being kept clean, in adequate thermal conditions and prevented from falling or slipping
- ▶ Are protected from injury
- ▶ Are handled and housed taking into consideration their normal behaviour
- ▶ Do not show signs of avoidable pain or fear or exhibit abnormal behaviour
- ▶ Do not suffer from prolonged withdrawal of feed or water
- ▶ Are prevented from avoidable interaction with other animals that could harm their welfare

In addition:

- ▶ Bring the animal into the stun box only when the operator is ready to stun it
- ▶ Avoid excessive light and noise at the stun box to keep animal stress to a minimum
- ▶ The operator should not have to concentrate on keeping his balance, or have to bend excessively each time he stuns an animal, as this becomes tiring and can lead to inaccurate stunning. Stun box and race design is therefore of utmost importance for both animal welfare and the operator's health and safety
- ▶ The efficiency of each stunner is essential to ensuring an effective stun. Adhere to the cleaning and maintenance schedules detailed within this instruction manual
- ▶ Ensure at least 2 stunning tools are present near the stun box. If one stunner breaks down in use, then there must be a working second tool available, to ensure there is always a means of administering an effective stun to the target animal

NOTE - we always advise you refer to any local regulations in force.

CASH® Special & CASH® Special Concussion EFFECTIVE STUNNING AND CARTRIDGE SELECTION

This section provides a guide to the correct stunning position and direction for certain animals, and helps you to select the correct cartridge for that animal.

The cartridge selection information provided within this section of this instruction manual is not categorical and is hence supplied as guidance only.

GOOD PRACTISE

- ▶ Understand animal welfare - refer to the Animal Welfare section for further guidance
- ▶ Always ensure your stunning tool is in good working order
- ▶ Stunning tools should be cleaned and maintained in accordance with the instructions within this manual
- ▶ Ensure at least 2 stunning tools are present near the stun box
- ▶ Stunning tools will require more maintenance if used with cartridges that are more powerful than is necessary for the target animal

EFFECTIVE STUNNING

The cartridge selection and the blow being applied to the correct part of the skull and in the right direction is important in ensuring an effective stun. Refer to the diagrams and selection charts within this section as guidance towards selection. To obtain maximum effect, the muzzle of the stunner must always be held firmly against the head.

The physical signs of an effective stun are:

Quadrupeds

- ▶ Animal collapses
- ▶ No rhythmic breathing
- ▶ Fixed, glazed expression in the eyes
- ▶ No corneal reflex
- ▶ Relaxed jaw
- ▶ Tongue hanging loose

Poultry

- ▶ Uncontrolled, severe wing flapping
- ▶ No rhythmic breathing immediately after stun
- ▶ No control over neck movement
- ▶ Leg flexion and extension
- ▶ Fixed, glazed expression in the eyes

THE EFFECTIVENESS OF THE STUN MUST BE VERIFIED BEFORE THE ANIMAL IS SLAUGHTERED.

FAILURE TO STUN

If an animal is not properly stunned it must be re-stunned immediately. Using the second or an alternative stunning tool, a repeat shot must always be placed so as to avoid the immediate area of the first shot.

STUN-TO-STICK TIMES

The humane killing of livestock using captive-bolt equipment is a two-stage procedure. After the animal has been stunned, it must be bled (or pithed*) immediately to ensure rapid death.

The stun-to-stick interval is the time from the application of stunning equipment to the start of bleeding. After stunning, sticking should be conducted without delay with a maximum stun-to-stick interval of 15 seconds recommended for all species in the field. In the abattoir all pigs, sheep and goats should also be stuck within 15 seconds. However, on the majority of cattle lines, where the carcass must be hoisted to a bleed area, maximum stun-to-stick intervals of 60 seconds for the penetrative captive-bolt and 30 seconds for the non-penetrative captive-bolt are acceptable. (Figures are obtained from the Humane Slaughter Association (HSA) website).

* Dependant upon localised regulations in force.

CASH® Special & CASH® Special Concussion
**EFFECTIVE STUNNING AND
 CARTRIDGE SELECTION**

CORRECT STUNNING POSITION

CATTLE

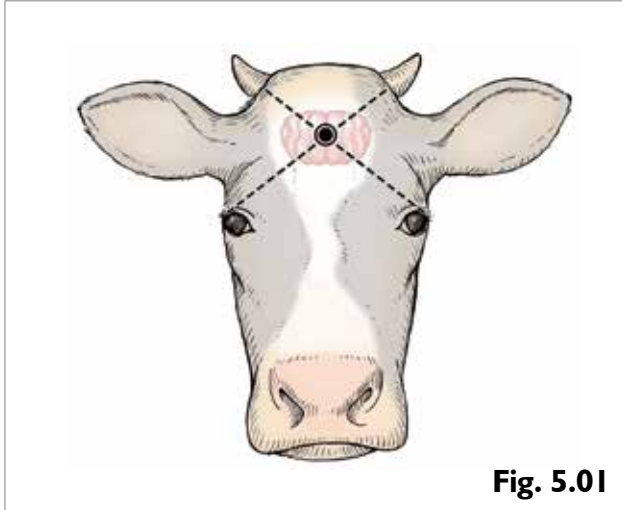

Fig. 5.01

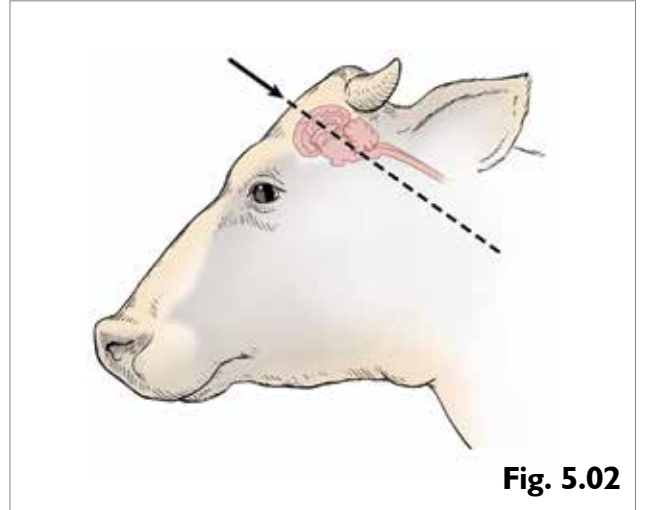

Fig. 5.02

Positioning imagery courtesy of J.K. Shearer, Iowa State University.

	SUGGESTED TOOLS AND CARTRIDGES			
	.22" RANGE		.25" RANGE	
	CASH SPECIAL CONCUSSION	CASH SPECIAL	CASH SPECIAL CONCUSSION	CASH SPECIAL
				
CALVES	PINK	PINK	PINK	PINK
LIGHT ANIMALS	PURPLE	PURPLE	YELLOW	YELLOW
MEDIUM ANIMALS	N/S	GREEN	N/S	BLUE
HEAVY ANIMALS & BULLS	N/S	RED*	N/S	ORANGE*
VERY HEAVY ANIMALS	N/S	N/S	N/S	N/S
EXTREMELY HEAVY ANIMALS	N/S	N/S	N/S	N/S

* HEAVY DUTY CASH SPECIAL ONLY
 N/S - NOT SUITABLE FOR DENOTED ANIMAL SIZE

CORRECT STUNNING POSITION

PIGS

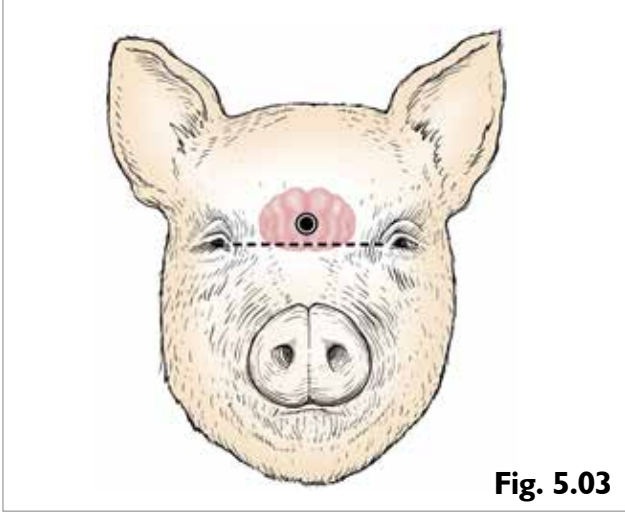

Fig. 5.03

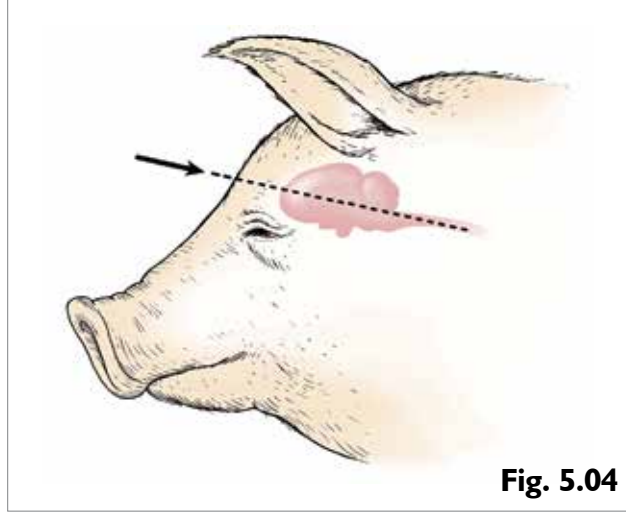

Fig. 5.04

Positioning imagery courtesy of J.K. Shearer, Iowa State University.

SUGGESTED TOOLS AND CARTRIDGES

	.22" RANGE		.25" RANGE	
	CASH SPECIAL CONCUSSION	CASH SPECIAL	CASH SPECIAL CONCUSSION	CASH SPECIAL
				
PIGLETS BELOW 5kg	BROWN	BROWN	PINK	PINK
WEANERS & GROWERS	PINK	PINK / PURPLE	PINK / YELLOW	YELLOW
MARKET PIGS	N/S	GREEN	N/S	BLUE
HEAVY ANIMALS	N/S	RED*	N/S	ORANGE*
HEAVY SOWS & BOARS	N/S	N/S	N/S	N/S

* HEAVY DUTY CASH SPECIAL ONLY
 N/S - NOT SUITABLE FOR DENOTED ANIMAL SIZE

CASH® Special & CASH® Special Concussion
**EFFECTIVE STUNNING AND
 CARTRIDGE SELECTION**

CORRECT STUNNING POSITION

SHEEP AND GOATS

Positioning imagery courtesy of J.K. Shearer, Iowa State University.

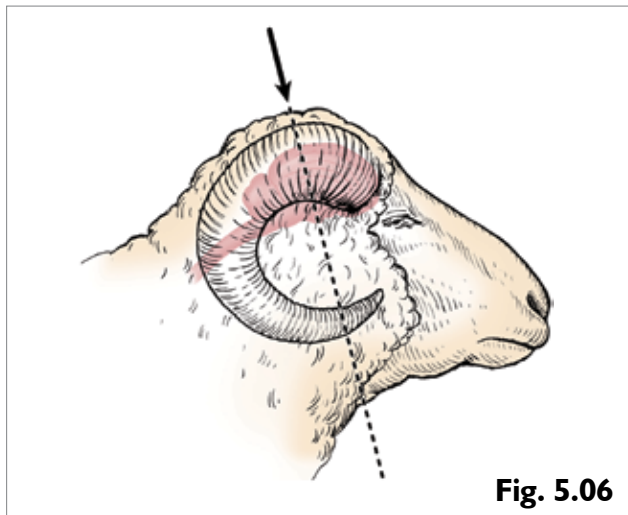
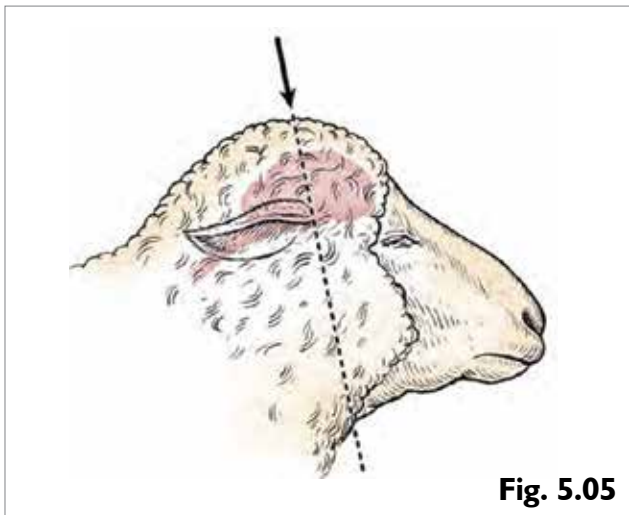

SUGGESTED TOOLS AND CARTRIDGES

	.22" RANGE		.25" RANGE	
	CASH SPECIAL CONCUSSION	CASH SPECIAL	CASH SPECIAL CONCUSSION	CASH SPECIAL
				
LAMBS & KIDS BELOW 5KG	BROWN	BROWN	PINK	PINK
LAMBS & KIDS ABOVE 5KG	PINK	PINK	PINK / YELLOW	PINK
EWES	PINK / PURPLE	PINK	PINK / YELLOW	PINK / YELLOW
RAMS	PURPLE	PURPLE	YELLOW	YELLOW
GOATS	PURPLE	PURPLE	YELLOW	YELLOW

OTHER ANIMAL SPECIES

Although Accles & Shelvoke stunning tools are predominantly used for the stunning of cattle, sheep and pigs for meat production, we know from our 100 year history that they are also used for other animal species, such as, but not limited to:

Mammals such as:	Birds such as:	Large fish such as:	Large reptiles such as:
Equines	Chickens	Sturgeon	Alligators
Deer	Turkeys	Tuna	Crocodiles
Camelids	Game birds	Etc	Monitor lizards
Etc	Etc		Etc

As conclusive test results are not available for these animals, we recommend you seek the advice of an independent expert to understand the appropriate cartridge selection, head placement and tool direction, prior to stunning.

ACCLES & SHELVOKE CARTRIDGE RANGE

The tables on the next pages identify which cartridges from our range are suitable for use with a given tool from the CASH Special range of products. The cartridges are supplied in quantities of 50 in a metal tin, or 1000 in a box. All of our products will be clearly branded as Accles & Shelvoke CASH cartridges.

It is a condition of Accles & Shelvoke’s product liability insurance that only CASH cartridges, in CASH cartons and bearing “E” or “C” headmarks, be used in stunners manufactured by Accles & Shelvoke. It follows therefore, that no liability whatsoever can be accepted for any claim, including injury, should any other brand of cartridge be used.

Where cartridges other than these are used, Accles & Shelvoke will not accept responsibility for:

- ▶ The safety of the operator
- ▶ The humaneness of the stun
- ▶ The correct operation of the stunning tool
- ▶ The premature failure of parts

Cartridges must be stored in cool, dry conditions. Exposure to excessive amounts of moisture may affect cartridge performance, which in turn will affect tool performance with the potential to create an ineffective stun of the animal.

When not in use, cartridges should be locked away separately from any stunning tools.

NOTE - “N/S” - WITH REFERENCE TO THE COMPATABILITY TABLES IN THIS SECTION OF THE MANUAL, “N/S” IDENTIFIES THAT THE CARTRIDGES HIGHLIGHTED ARE NOT SUITABLE FOR USE IN THE STATED CASH SPECIAL PRODUCT IN THE TABLE.



EXCEEDING THE PERMITTED STRENGTH OF CARTRIDGE COULD BE HAZARDOUS TO THE OPERATOR, WILL REDUCE THE EXPECTED LIFE OF THE TOOL OR ITS COMPONENTS AND WILL INVALIDATE OUR WARRANTY

CASH® Special & CASH® Special Concussion
EFFECTIVE STUNNING AND
CARTRIDGE SELECTION

STUNNING TOOL & CARTRIDGE COMPATABILITY - .25" CALIBRE									
			1.25 GRAIN	2 GRAIN	3 GRAIN	3.5 GRAIN	4 GRAIN	4.5 GRAIN	6 GRAIN
CALIBRE	PRODUCT CODE	DESCRIPTION	PINK	YELLOW	BLUE	ORANGE	BLACK	GREEN	RED
.25"	412I	CASH Special .25	YES	YES	N/S				
	412IK	CASH Dispatch Kit	YES	YES	YES	YES	N/S		
	412IR	CASH Special .25R	YES	YES	YES	N/S			
	412IHD	CASH Special .25R HD	YES	YES	YES	YES	N/S		
	412IHL	CASH Special .25R HL	YES	YES	YES	YES	N/S		
	4122	CASH Special .25 Concussion	YES	YES	N/S				

To order your .25" calibre cartridges, please select the appropriate part number from the table below:

PART NUMBERS FOR .25" CARTRIDGES BY QUANTITY			
SIZE	COLOUR	50 IN A TIN	1000 IN A BOX
1.25 GRAIN	PINK	412IKA	7760
2 GRAIN	YELLOW	412IKB	7710
3 GRAIN	BLUE	412IKC	7757
3.5 GRAIN	ORANGE	412IKD	7748
4 GRAIN	BLACK	7754T	7754
4.5 GRAIN	GREEN	7725T	7725
6 GRAIN	RED	7705T	7705

CASH® Special & CASH® Special Concussion
EFFECTIVE STUNNING AND
CARTRIDGE SELECTION

STUNNING TOOL & CARTRIDGE COMPATABILITY - .22" CALIBRE								
			1 GRAIN	1.25 GRAIN	2.5 GRAIN	3 GRAIN	4 GRAIN	4.5 GRAIN
CALIBRE	PRODUCT CODE	DESCRIPTION	BROWN	PINK	PURPLE	GREEN	RED	BLACK
.22"	4100R	CASH Special .22R	YES	YES	YES	YES	N/S	
	4000	CASH Special .22 HD	YES	YES	YES	YES	YES	N/S
	4002	CASH Special .22 Concussion	YES	YES	YES	N/S		

To order your .22" calibre cartridges, please select the appropriate part number from the table below:

PART NUMBERS FOR .22" CARTRIDGES BY QUANTITY			
SIZE	COLOUR	50 IN A TIN	1000 IN A BOX
1 GRAIN	BROWN	7505T	7505
1.25 GRAIN	PINK	7585T	7585
2.5 GRAIN	PURPLE	7565T	7565
3 GRAIN	GREEN	7632T	7632
4 GRAIN	RED	7645T	7645
4.5 GRAIN	BLACK	7653T	7653

KEY PARAMETERS FOR CARTRIDGE SELECTION

The table on the next page details the key performance parameters for the CASH Special range of tools when used in conjunction with approved Accles & Shelvoke cartridges.

This information is issued to satisfy the requirements of EU Council Regulation (EC) Number 1099/2009 on the protection of animals at the time of killing. It provides guidelines to aid the selection of an appropriate cartridge to perform effective stunning on a particular type and size of animal. Whilst we believe this regulation is open to interpretation, these parameters have been published following years of experience.

These figures may only be used when quoted with the associated notes. Accles & Shelvoke will not accept responsibility for the reliability of these figures if used out of context.

CASH® Special & CASH® Special Concussion EFFECTIVE STUNNING AND CARTRIDGE SELECTION

PRODUCT CODE	CALIBRE	CARTRIDGE GRAINS (NOMINAL)	ACCLES & SHELVOKE CARTRIDGE COLOUR	# BOLT (HEAD) DIAMETER (MM)	AVERAGE BOLT VELOCITY* (M/S)	MINIMUM BOLT EXIT LENGTH** (MM)	ENERGY GENERATED (J)
4100R	.22"	1	BROWN	11.4	34.2 *	65	122
		1.25	PINK	11.4	42.3 *	65	189
		2.5	PURPLE	11.4	47.5 *	65	238
		3	GREEN	11.4	52.5 *	65	291
4000	.22"	1	BROWN	11.4	33.0 *	65	114
		1.25	PINK	11.4	41.5 *	65	182
		2.5	PURPLE	11.4	46.5 *	65	227
		3	GREEN	11.4	51.4 *	65	277
		4	RED	11.4	55.6 *	65	325
4002	.22"	1	BROWN	11.4 / 38.3	23.1 ~	35	76
		1.25	PINK	11.4 / 38.3	30.6 ~	35	133
		2.5	PURPLE	11.4 / 38.3	35.6 ~	35	180
4121	.25"	1.25	PINK	11.4	39.7 *	65	165
		2	YELLOW	11.4	48.7 *	65	249
4121R	.25"	1.25	PINK	11.4	39.7 *	65	165
		2	YELLOW	11.4	48.7 *	65	249
		3	BLUE	11.4	53.1 *	65	296
4121HD	.25"	1.25	PINK	11.4	38.7 *	65	163
		2	YELLOW	11.4	47.2 *	65	243
		3	BLUE	11.4	51.4 *	65	288
		3.5	ORANGE	11.4	54.0 *	65	329
4121HL	.25"	1.25	PINK	11.4	38.1 *	65	167
		2	YELLOW	11.4	46.3 *	65	247
		3	BLUE	11.4	50.8 *	65	297
		3.5	ORANGE	11.4	53.7 *	65	332
4122	.25"	1.25	PINK	11.4 / 38.3	30.2 ~	35	129
		2	YELLOW	11.4 / 38.3	34.0 ~	35	164
DISPATCH KIT	SHORT BOLT COMBINATION	1.25	PINK	11.4	40.5 <	45	154
		2	YELLOW	11.4	50.1 <	45	236
		3	BLUE	11.4	54.9 <	45	283
		3.5	ORANGE	11.4	57.1 <	45	306
	MEDIUM BOLT COMBINATION	1.25	PINK	11.4	38.7 *	65	163
		2	YELLOW	11.4	47.2 *	65	243
		3	BLUE	11.4	51.4 *	65	288
		3.5	ORANGE	11.4	54.0 *	65	329
	LONG BOLT COMBINATION	1.25	PINK	11.4	38.1 *	65	167
		2	YELLOW	11.4	46.3 *	65	247
		3	BLUE	11.4	50.8 *	65	297
		3.5	ORANGE	11.4	53.7 *	65	332
	CONCUSSION COMBINATION	1.25	PINK	11.4 / 38.3	30.2 ~	35	129
		2	YELLOW	11.4 / 38.3	34.0 ~	35	164

Notes

- * When measured in air over a distance of 47mm, 15mm from the muzzle tip of the tool.
- ** When fired in air
- # For Concussion tools, bolt and concussion head diameters quoted
- ~ When measured in air over a distance of 20mm, 10mm from the muzzle tip of the tool.
- < When measured in air over a distance of 40mm, 15mm from the muzzle tip of the tool.

The velocity figures quoted are accurate within +/- 10%, when using a stunner that is in good condition and maintained in accordance with this instruction manual.





ALWAYS WEAR THE CORRECT PERSONAL PROTECTIVE EQUIPMENT (PPE) WHENEVER YOU ARE WORKING WITH, CLEANING OR MAINTAINING YOUR CASH SPECIAL TOOL. ALWAYS WEAR PROTECTIVE GLASSES AND HEARING PROTECTION. THE CORRECT FOOT PROTECTION MUST BE WORN. THERE IS A RISK THAT IF THE TOOL IS DROPPED, THE BOLT MAY PENETRATE THE FOOT OF THE TOOL USER.



ALWAYS POINT THE TOOL AWAY FROM YOUR BODY AND AWAY FROM ANY OTHER PERSON IN THE VICINITY WHEN HANDLING OR OPERATING THE TOOL

GENERAL SAFETY STATEMENT

- ▶ THE INTENDED USE OF THIS TOOL IS FOR THE STUNNING OF ANIMALS PRIOR TO SLAUGHTER OR DEPOPULATION
- ▶ ANYONE GRANTED THE AUTHORITY TO USE ONE OF THESE TOOLS TO STUN ANIMALS SHOULD HAVE READ THIS INSTRUCTION MANUAL SUCH THAT THEY ARE MADE FULLY AWARE OF THE POTENTIAL RISKS
- ▶ THIS TOOL HAS THE POTENTIAL TO CAUSE SEVERE INJURY OR FATALITY IF USED IMPROPERLY OR INAPPROPRIATELY OUTSIDE OF ITS INTENDED SCOPE OF USE



DANGER - The hazards listed in this section pose a high level of risk which, if not avoided will result in death or serious injury

- ▶ NEVER POINT THE STUNNING TOOL AT YOURSELF OR ANY OTHER PERSON - THE BOLT WILL PENETRATE BODY PARTS AND MAY LEAD TO SEVERE AND IRREVERSIBLE DAMAGE, POSSIBLY LEADING TO FATALITY
- ▶ NEVER FIRE THE STUNNING TOOL IN AN AREA DESIGNATED AS FLAMMABLE OR CONTAINING EXPLOSIVES
- ▶ NEVER PASS THE TOOL TO ANY OTHER PERSON WHEN IT IS COCKED AND READY TO FIRE - ACCIDENTAL FIRING OF THE BOLT WILL PENETRATE BODY PARTS AND MAY LEAD TO SEVERE AND IRREVERSIBLE DAMAGE POSSIBLY LEADING TO FATALITY
- ▶ NEVER LEAVE A CARTRIDGE, WHETHER LIVE OR FIRED, IN THE BREECH - TO PREVENT ACCIDENTAL FIRING OF THE BOLT
- ▶ TOOLS SHOULD BE FIRED AS FAR AWAY FROM THE BODY AS IS COMFORTABLE AND ALWAYS POINTING AWAY FROM THE OPERATOR - FIRING OF THE BOLT TOWARD BODY PARTS MAY PENETRATE THE BODY AND MAY LEAD TO SEVERE AND IRREVERSIBLE DAMAGE, POSSIBLY LEADING TO FATALITY
- ▶ ONLY EVER COCK THE TOOL (MAKE READY FOR FIRING) IMMEDIATELY BEFORE FIRING - TO MINIMISE THE RISK OF DROPPING THE TOOL AND/OR ACCIDENTAL FIRING
- ▶ NEVER MODIFY OR CUSTOMISE THE TOOL - THIS MAY RENDER THE TOOL UNSTABLE AND UNSAFE FOR USE, WITH THE POTENTIAL TO FIRE ACCIDENTALLY. IT WILL ALSO INVALIDATE YOUR WARRANTY
- ▶ ENSURE YOU ARE BALANCED AND STABLE PRIOR TO FIRING TO AID TOOL POSITIONING ACCURACY. AVOID OVER-STRETCHING AND UNFAVOURABLE BODY POSITIONS - TO MINIMISE THE RISK OF DROPPING THE TOOL AND/OR ACCIDENTAL FIRING
- ▶ CARTRIDGE MISFIRES - IF THE CARTRIDGE HAS MISFIRED (NOT FIRED), PUT THE TOOL DOWN IMMEDIATELY AND WAIT FOR 30 SECONDS BEFORE FOLLOWING THE PROCEDURE IN SECTION 9 OF THIS MANUAL - TO AVOID DELAYED FIRING OF THE CARTRIDGE - WHICH MAY CAUSE SEVERE DAMAGE IF FIRING OCCURS WHILST BEING HANDLED



WARNING - The hazards listed in this section pose a medium level of risk which, if not avoided may result in recoverable injury

- ▶ DO NOT FIRE THE BOLT INTO HARD, BRITTLE OR IMPENETRABLE MATERIALS - AS THE BOLT MAY FRAGMENT AND POSE A DANGER OF FLYING PARTICLES
- ▶ NEVER USE A MORE POWERFUL CARTRIDGE THAN THE MAXIMUM PERMITTED CARTRIDGE AS STAMPED ON YOUR STUNNING TOOL - TO PREVENT CARTRIDGE BURST AND EXCESSIVE NOISE IN OPERATION
- ▶ KEEP THE TOOL DRY AND CLEAN - TO ENSURE YOU HAVE AN ADEQUATE GRIP ON THE TOOL DURING USE AND MINIMISE THE RISK OF DROPPING THE TOOL
- ▶ IF THE TOOL IS ACCIDENTALLY DROPPED, ENSURE THE POLEAXE END OF THE BOLT IS NOT DAMAGED AND THAT THE TRIGGER/FIRING BLOCK/HAMMER ARRANGEMENT IS WORKING CORRECTLY BEFORE RE-USING - IF IN DOUBT, THE TOOL SHOULD BE CHECKED AND REPAIRED AS NECESSARY
- ▶ DO NOT TRY TO CATCH A TOOL IF IT IS DROPPED - LET IT FALL TO THE FLOOR AND MOVE YOURSELF AWAY FROM THE TOOL, ONLY APPROACHING IT AFTER IT IS STATIONARY



CAUTION - The hazards listed in this section pose a low level of risk which, if not avoided may result in minor or moderate injury

- ▶ KEEP FINGERS AWAY FROM THE FIRING MECHANISM WHEN THE TOOL IS READY TO FIRE - TO PREVENT TRAPPING.



ALWAYS WEAR THE CORRECT PERSONAL PROTECTIVE EQUIPMENT (PPE) WHENEVER YOU ARE WORKING WITH, CLEANING OR MAINTAINING YOUR CASH SPECIAL TOOL. ALWAYS WEAR PROTECTIVE GLASSES AND HEARING PROTECTION. THE CORRECT FOOT PROTECTION MUST BE WORN. THERE IS A RISK THAT IF THE TOOL IS DROPPED, THE BOLT MAY PENETRATE THE FOOT OF THE TOOL USER.



ALWAYS POINT THE TOOL AWAY FROM YOUR BODY AND AWAY FROM ANY OTHER PERSON IN THE VICINITY WHEN HANDLING OR OPERATING THE TOOL

GENERAL PRECAUTIONS AND GOOD PRACTISE

IMPROPER USE

- ▶ ONLY EVER USE THIS TOOL FOR THE STUNNING OF LIVE ANIMALS
- ▶ ONLY EVER USE GENUINE ACCLES AND SHELVOKE SUPPLIED CARTRIDGES AND SPARES
- ▶ DO NOT FIRE "AIR SHOTS" (FIRING OF THE BOLT INTO AIR) AS THIS WILL REDUCE THE WORKING LIFE OF THE TOOL AND ITS COMPONENTS

WORKPLACE PRECAUTIONS

- ▶ THE TOOL SHOULD BE USED IN WELL ILLUMINATED AND WELL VENTILATED WORKPLACE ENVIRONMENTS
- ▶ ENSURE THE WORKPLACE IS FREE OF UNNECESSARY OBSTACLES OR TRIP HAZARDS

OPERATIONAL PRECAUTIONS

- ▶ ONLY LOAD CARTRIDGES WHEN THEY ARE READY TO BE USED
- ▶ IF A CARTRIDGE STICKS IN THE BREECH AND WILL NOT EJECT, DO NOT USE A SHARP INSTRUMENT TO REMOVE. THE TOOL SHOULD BE REMOVED IN ACCORDANCE WITH THESE INSTRUCTIONS IN SECTION 9 - TROUBLESHOOTING
- ▶ TOOLS MAY BE USED IN AN ALTERNATING SYSTEM AS PART OF A PLANNED OPERATING CYCLE
- ▶ JOB ROTATION MAY HELP MAINTAIN THE APPROPRIATE HIGH LEVELS OF CONCENTRATION REQUIRED AT THE WORKPLACE, HELPING TO MINIMISE ANY RISK DUE TO TIREDNESS OR FATIGUE

GOOD PRACTISE

- ▶ THE CLEANING AND MAINTENANCE SCHEDULE DETAILED IN THIS MANUAL SHOULD BE ADHERED TO, TO ENSURE THE TOOL OPERATES SAFELY AND CORRECTLY TO PROVIDE EFFECTIVE ANIMAL STUNNING
- ▶ AT THE END OF A WORKING SHIFT, OR IF THE TOOL IS NOT GOING TO BE USED FOR PROLONGED PERIODS, THE UNCOCKED AND UNLOADED TOOL SHOULD BE STORED IN COOL DRY CONDITIONS AND LOCKED SECURELY IN A WAY THAT NO UNAUTHORISED ACCESS TO THE TOOL IS POSSIBLE
- ▶ CARTRIDGES SHOULD BE LOCKED AWAY SEPARATELY FROM THE STUNNING TOOL IN COOL, DRY CONDITIONS
- ▶ EXPOSURE TO EXCESSIVE AMOUNTS OF MOISTURE MAY AFFECT CARTRIDGE PERFORMANCE WHICH IN TURN WILL AFFECT TOOL PERFORMANCE, WITH THE POTENTIAL TO CREATE AN INEFFECTIVE STUN OF THE ANIMAL. WET CARTRIDGES WILL NOT FIRE AND SHOULD NOT BE USED
- ▶ ALWAYS WASH YOUR HANDS AFTER USING ANY STUNNING TOOL TO ENSURE CLEANLINESS

TRANSPORTATION OF STUNNING TOOLS AND CARTRIDGES BETWEEN SITES

THIS TOOL HAS BEEN SUPPLIED TO YOU WITH THE INTENTION OF SINGLE SITE USE - SUPPLIED WITHOUT A LOCKABLE STORAGE CONTAINER. SHOULD THERE BE A NEED TO TRANSPORT THIS TOOL AND LIVE CARTRIDGES BY ROAD BETWEEN SITES, WE ADVISE:-

- ▶ PRIOR TO TRANSPORTATION, YOU SHOULD SEEK THE APPROPRIATE ADVICE CONCERNING APPLICABLE LOCAL LAWS AND REGULATIONS IN FORCE ON THE TRANSPORTATION OF CARTRIDGES TO BE USED FOR ANIMAL STUNNING
- ▶ THE TOOL AND CARTRIDGES ARE TRANSPORTED IN SEPARATE LOCKABLE CONTAINERS
- ▶ THEY ARE HIDDEN FROM PUBLIC VIEW, ie NO-ONE OUTSIDE OF THE VEHICLE CAN SEE THE LOCKABLE CONTAINERS WITHIN THE VEHICLE.

CASH® Special & CASH® Special Concussion SAFE OPERATING INSTRUCTIONS

 **DO NOT ATTEMPT TO USE THIS STUNNING TOOL UNTIL YOU HAVE READ AND UNDERSTOOD THESE INSTRUCTIONS.**



ALWAYS WEAR THE CORRECT PERSONAL PROTECTIVE EQUIPMENT (PPE) WHENEVER YOU ARE WORKING WITH, CLEANING OR MAINTAINING YOUR CASH SPECIAL TOOL. ALWAYS WEAR PROTECTIVE GLASSES AND HEARING PROTECTION. THE CORRECT FOOT PROTECTION MUST BE WORN. THERE IS A RISK THAT IF THE TOOL IS DROPPED, THE BOLT MAY PENETRATE THE FOOT OF THE TOOL USER.

 **ALWAYS POINT THE TOOL AWAY FROM YOUR BODY AND AWAY FROM ANY OTHER PERSON IN THE VICINITY WHEN HANDLING OR OPERATING THE TOOL**

NOTE

- ▶ The maximum recommended usage rate for a CASH Special tool is 60 shots per hour using the maximum specified cartridge

1 PREPARING FOR LOADING

- 1.1 Pull back the hammer. The hammer will “CLICK” into place and remain latched open**
- 1.2 Pull back the firing block. The firing block will “CLICK” into place and remain latched open, as shown in Fig. 7.0**

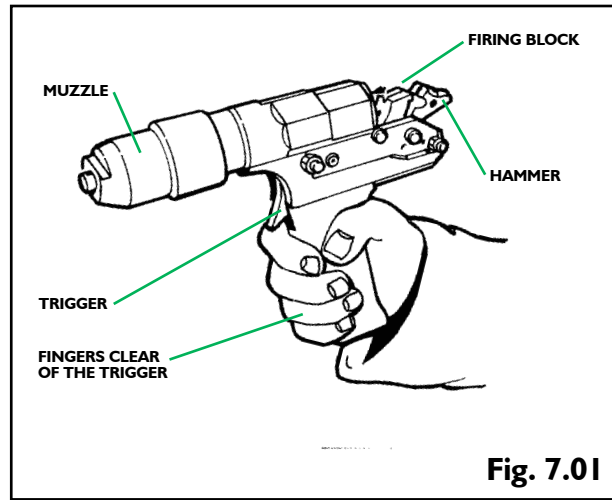

Fig. 7.01

©2016 Accles & Shelvoke

NOTE

- ▶ Pulling back the firing block operates the extractor. The extractor is designed to lift a spent cartridge away from the breech to aid the removal of that cartridge

2 LOADING

- 2.1 Obtain a single cartridge, and load into the cartridge chamber crimped end first, as shown in Fig. 7.03**

NOTE

- ▶ Only load the cartridge immediately before firing
- ▶ Keep the cartridge clean and dry before insertion into the chamber
- ▶ Visually check the bolt is fully retracted (refer to Fig. 7.02)
- ▶ Only use the correct grade of CASH cartridge bearing the “E” or “C” headmark, as shown in Fig. 7.04
- ▶ When not in use, never leave a cartridge in the chamber, whether live or spent
- ▶ Never leave a loaded stunner unattended

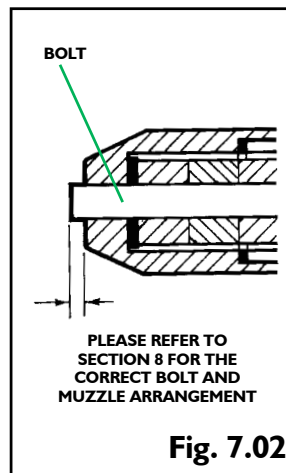

Fig. 7.02

©2016 Accles & Shelvoke

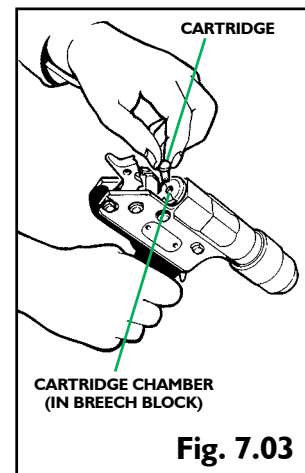

Fig. 7.03

©2016 Accles & Shelvoke

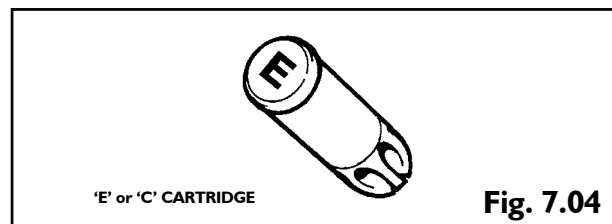

Fig. 7.04

©2016 Accles & Shelvoke

CASH® Special & CASH® Special Concussion SAFE OPERATING INSTRUCTIONS



ALWAYS POINT THE TOOL AWAY FROM YOUR BODY AND AWAY FROM ANY OTHER PERSON IN THE VICINITY WHEN HANDLING OR OPERATING THE TOOL

3 MAKE READY FOR FIRING

- 3.1** With the tool pointing away from you, push the firing block forward so it contacts the breech face, as shown in Fig. 7.05. The tool is now 'cocked' and ready to fire

NOTE

- ▶ Do not point the tool at yourself or any other person
- ▶ Keep your fingers away from and clear of the trigger

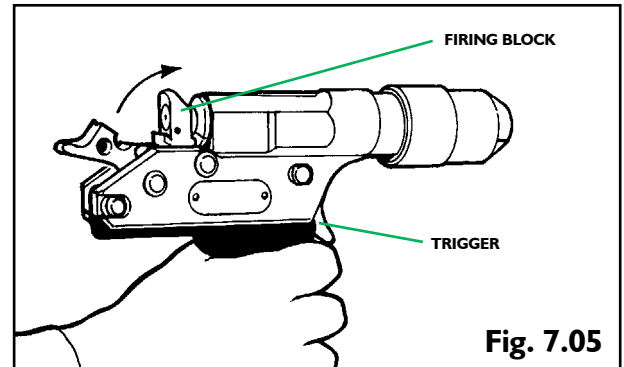

©2016 Accles & Shelvoke

4 FIRE

- 4.1** Position the muzzle tip into the correct position on the target animal's head and when it touches, you should instantaneously fire the tool by pulling the trigger to stun the animal

NOTE

- ▶ Refer to section 5 - Effective stunning and cartridge selection for the correct stunning position and angle for the target animal
- ▶ Do not attempt to FIRE if the animal is moving its head
- ▶ The muzzle application must be smooth and accurate and the tool fired the instant it is in position on the target area of the head
- ▶ Hold the tool with one hand only. Do not use your free hand to hold or steady the tool
- ▶ Keep your fingers clear of the hammer when firing to avoid trapping them

5 EXTRACTION

- 5.1** Pull back the hammer and firing block as shown in Fig. 7.01
- 5.2** Remove the spent cartridge as shown in Fig. 7.06
- 5.3** The tool is now ready for the next cartridge



IF THE CARTRIDGE HAS MISFIRED (NOT FIRED), PUT THE TOOL DOWN IMMEDIATELY AND WAIT FOR 30 SECONDS BEFORE FOLLOWING THE PROCEDURE IN SECTION 9 OF THIS MANUAL

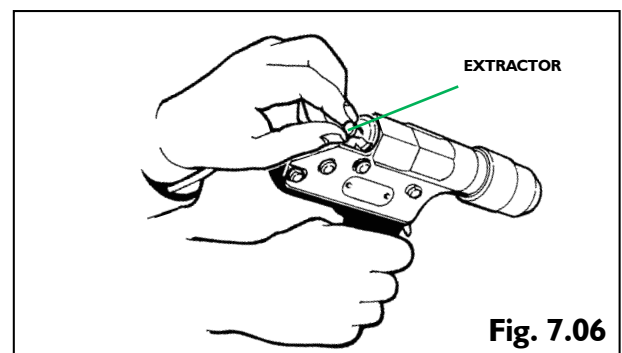

©2016 Accles & Shelvoke

NOTE

- ▶ The spent cartridge will be partially lifted by the extractor to make removal easier
- ▶ If the spent cartridge is stuck in the chamber, follow the procedure in Section 9 of this manual to remove safely
- ▶ Do not use a sharp implement to remove stuck cartridges as this may damage the breech or extractor

CASH® Special & CASH® Special Concussion CLEANING AND GENERAL MAINTENANCE



DO NOT ATTEMPT TO USE THIS STUNNING TOOL UNTIL YOU HAVE READ AND UNDERSTOOD THESE INSTRUCTIONS.



ALWAYS WEAR THE CORRECT PERSONAL PROTECTIVE EQUIPMENT (PPE) WHENEVER YOU ARE WORKING WITH, CLEANING OR MAINTAINING YOUR CASH SPECIAL TOOL. ALWAYS WEAR PROTECTIVE GLASSES AND HEARING PROTECTION. THE CORRECT FOOT PROTECTION MUST BE WORN. THERE IS A RISK THAT IF THE TOOL IS DROPPED, THE BOLT MAY PENETRATE THE FOOT OF THE TOOL USER.

TO ENSURE YOUR CASH SPECIAL STUNNING TOOL IS WORKING TO ITS OPTIMUM PERFORMANCE, WE RECOMMEND IT IS CHECKED ON AN ACCLES & SHELVOKE UNIVERSAL STUN CHECK UNIT AFTER CLEANING OR MAINTENANCE AND BEFORE DAILY USE.

PART NO.	DESCRIPTION	QTY PER SET	ITEM NO*
4107	Breech Cleaner	1	43
4191	Undercut Cleaner	1	44
4119	Push Rod	1	45
4136	Spanner (for handle barrel bolt nuts)	1	46
4173	Hex Wrench (for extractor spring screw)	1	51
5647	Handle (for barrel brush)	1	54
5645	Brush Head (for barrel cleaning)	1	53
5900	Brush and Mop Handle	1	59
5901	.22" Chamber Brush #	1	60
5902	.25" Chamber Brush #	1	
5903	.22" Chamber Mop #	1	61
5904	.25" Chamber Mop #	1	
4306	14mm Cone Spanner ##	1	49
4307	16mm Cone Spanner ##	1	50
4187	Pistol Oil **	0	47
4192	Copaslip Thread Grease **	0	48
6076	Youngs 303 Fluid **	0	not shown

Note - item numbers quoted in this section refer to the parts indicated by that item number in the spares diagram and spares list in Section 11 of this manual.

TABLE NOTES

Items highlighted above are included with every CASH Special Tool. The non-highlighted items are available as maintenance spares.
* Item No. on Maintenance Spares List in Section 11
** Product Data Sheets available upon request
Brush and Mop supplied in accordance with the calibre of tool
Supplied with Concussion tools only

MAINTENANCE AND CLEANING RECORD

It is a requirement of EU COUNCIL REGULATION (EC) No 1099/2009 - On the protection of animals at the time of killing, that all stunning equipment is maintained in accordance with the manufacturers' instructions and that a log detailing the maintenance is recorded and available for external auditing purposes.

We recommend you create a maintenance and cleaning record for each individual stunning tool, containing as a minimum the following information

- ▶ Stunner product code and description
- ▶ Serial number
- ▶ Service start date (date tool was first used)
- ▶ Cleaning dates - both daily and weekly (in accordance with the cleaning stated in this instruction manual)
- ▶ Part replacement details - part number and description - date replacement/maintenance took place
- ▶ Stun Check record - Universal Stun Check unit serial number, date checked, cartridge colour used, pass or fail
- ▶ Shots fired - total number of shots fired with the tool on a daily or weekly basis
- ▶ Name and position of person conducting the cleaning or maintenance on any given day

ONLY EVER USE GENUINE ACCLES & SHELVOKE REPLACEMENT PARTS. NOT USING GENUINE PARTS MAY LEAD TO PREMATURE COMPONENT AND TOOL FAILURE, WHICH COULD ENDANGER THE OPERATOR AND THOSE IN THE IMMEDIATE VICINITY. IT WILL ALSO INVALIDATE OUR ORIGINAL EQUIPMENT WARRANTY.

ACCLES & SHELVOKE WILL ACCEPT NO LIABILITY IF ANY COMPONENTS OTHER THAN THOSE SUPPLIED BY ACCLES & SHELVOKE ARE USED WITH OUR ORIGINAL EQUIPMENT. THE RESULTANT LIABILITY WILL BE WITH THE END USER OR THE DISTRIBUTOR WHO SUPPLIED THE UNAPPROVED REPLACEMENT PARTS.

CLEANING AND GENERAL MAINTENANCE



ALWAYS POINT THE TOOL AWAY FROM YOUR BODY AND AWAY FROM ANY OTHER PERSON IN THE VICINITY WHEN HANDLING OR OPERATING THE TOOL

CLEANING DAILY - CASH Special

- 1 Pull back the hammer and firing block to ensure that the tool is not loaded.
- 2 Unscrew the muzzle from the barrel. If it is too tight, hold the flats on the muzzle in a vice fitted with soft jaws and unscrew, using the tool handle as a lever.
- 3 Withdraw the bolt assembly from the barrel. If it will not pull out of the barrel by hand, hold the barrel in a soft jawed vice and using the push rod (item 45), insert into the cartridge chamber and push or tap through to release the bolt assembly from the barrel.
- 4 Wipe the inside of the barrel with the barrel/muzzle brush (item 52) to remove any soft powder and residue.
- 5 Carefully insert the breech cleaner (item 43) as shown in Fig. 8.04 and Fig. 8.05 to clean the internal breech faces and piston bore. This is best done when the barrel is still warm after use, before the powder residue solidifies. Young's 303 fluid can be used if the powder is hard and difficult to remove. Excessive powder build up will reduce the performance of the tool.
- 6 Assemble the chamber brush (item 60) shown in Fig. 8.06 and the chamber mop (item 61) shown in Fig. 8.07 to the brush and mop handle (item 59), screwing together hand tight. Using the brush end, insert via the open barrel end, as shown in Fig 8.08, into the cartridge chamber, and with a turning action, push in and out of the chamber to remove all powder residue. Youngs 303 fluid can be used if the powder is difficult to remove. Apply some pistol oil to the mop head. Insert via the open barrel end into the cartridge chamber, and with a turning action, push in and out of the chamber to remove any remaining residue or powder.
- 7 Remove the washers and recuperator sleeves from the bolt. Using a wire brush, remove all powder deposits from the bolt, wiping with a lightly oiled cloth. Only use the recommended pistol oil (item 47) and do not over apply.
- 8 Examine washers and recuperator sleeves:
 - 8.1 Stop washer - item number 6 on Spares Diagram.
One of these washers is fitted at the poleaxe end of the bolt, up against the muzzle. Its function is to prevent the recuperator sleeve next to it from extruding through the clearance between the bolt and the muzzle bore. Once this washer shows wear on the inner hole edges or the outer edge, it must be replaced to prevent rapid recuperator sleeve wear.
 - 8.2 Flange washer - blue colour - item number 7 on Spares Diagram.
This washer is placed behind the last recuperator sleeve and the bolt piston (bolt flange). Once this washer shows wear on the outer edge, it must be replaced to prevent rapid recuperator sleeve wear.
 - 8.3 Recuperator sleeve - item number 8 on Spares Diagram.
The first and last sleeves on the bolt will be the first to show signs of wear. To extend their life and promote even wear of the set of sleeves, the end sleeves should be moved in toward the middle, being replaced by the outer or end sleeves. This may be repeated until they start to become badly worn and frayed, when they should be replaced. If rotated, and provided the stop and flange washers remain in good condition, a full set may last up to 5,000 shots.
 - 8.4 Muzzle barrel washer - item number 9 on spares diagram.
Once this washer shows excessive wear, it must be replaced to prevent rapid recuperator sleeve wear.



DO NOT NEGLECT THE WASHERS OR SLEEVES. TOOL PERFORMANCE WILL BE DIMINISHED IF THESE PARTS ARE NOT IN GOOD CONDITION

- 9 Wipe all steel components with an oiled cloth. Only use the recommended pistol oil (item 47) and do not over apply. Blow out any excess oil from the cartridge chamber.
- 10 Reassemble the bolt, washers and recuperator sleeves in the correct order and insert into the barrel.
- 11 Reassemble the muzzle and screw it hand tight onto the barrel, ensuring the poleaxe end of the bolt can be seen.
- 12 Lubricate the firing block pivot point, using 2 drops of pistol oil, as shown in Fig. 8.11.
- 13 Check the tool performance using a Universal Stun Check unit to ensure optimal tool performance.



IT IS IMPORTANT TO ENSURE YOU ARE USING THE CORRECT BOLT AND MUZZLE COMBINATION. THE POLEAXE END OF THE BOLT SHOULD BE VISIBLE PAST THE MUZZLE TIP AFTER ASSEMBLY TO THE BARREL

REFER TO FIG. 8.01 WHICH SHOWS A SECTION THROUGH EACH OF THE FOUR CORRECT BOLT/MUZZLE ARRANGEMENTS

IF THE BOLT IS NOT VISIBLE PAST THE MUZZLE TIP OR PROTRUDES TOO FAR COMPARED TO FIG. 8.01, YOU HAVE ASSEMBLED THE WRONG COMBINATION AND THE TOOL MUST NOT BE USED. RE-CHECK YOUR COMPONENTS TO ENSURE YOU HAVE THE CORRECT COMBINATION IN ACCORDANCE WITH FIG. 9.01, IN 'SECTION 9 – TROUBLESHOOTING'

CLEANING AND GENERAL MAINTENANCE



ALWAYS POINT THE TOOL AWAY FROM YOUR BODY AND AWAY FROM ANY OTHER PERSON IN THE VICINITY WHEN HANDLING OR OPERATING THE TOOL

CLEANING WEEKLY – CASH Special

- 1 Repeat steps 1 to 5 from Cleaning Daily above.
- 2 Grip the undercut cleaner (item 44) in a vice, cleaning head vertically up, as shown in Fig 8.09.
- 3 Locate the barrel assembly over the undercut cleaner such that it enters into the barrel bore, as shown in Fig. 8.10 until it touches onto the breech face.
- 4 Apply sideways pressure to the barrel so that the undercut cleaner head enters the undercut. Maintaining the sideways pressure, rotate the barrel clockwise and anticlockwise through 180° two or three times. Turn the barrel through 180° and repeat the process until the undercut has been thoroughly cleaned. The undercut needs to be kept clean as excessive powder build up will reduce the performance of the tool. The undercut cleaner will clean the front face of the breech block at the same time.
- 5 Check the vent holes in the barrel and muzzle are unblocked, clear if necessary.
- 6 Repeat steps 6 to 13 from Cleaning Daily - CASH Special.

CLEANING DAILY – CASH Special Concussion

- 1 Pull back the hammer and firing block to ensure that the tool is not loaded.
- 2 Unscrew the muzzle extension from the muzzle.
- 3 Unscrew the concussion head assembly from the barrel. If it is too tight, hold the flats on the muzzle in a vice fitted with soft jaws and unscrew, using the tool handle as a lever.
- 4 Wipe the inside of the barrel with the barrel/muzzle brush (item 52) to remove any soft powder and residue.
- 5 Carefully insert the breech cleaner (item 43) as shown in Fig. 8.04 and Fig. 8.05 to clean the internal breech faces and piston bore. This is best done when the barrel is still warm after use, before the powder residue solidifies. Young's 303 fluid can be used if the powder is hard and difficult to remove. Excessive powder build up will reduce the performance of the tool.
- 6 Assemble the chamber brush (item 60) shown in Fig. 8.06 and the chamber mop (item 61) shown in Fig. 8.07 to the brush and mop handle (item 59), screwing together hand tight. Using the brush end, insert via the open barrel end, as shown in Fig 8.08, into the cartridge chamber, and with a turning action, push in and out of the chamber to remove all powder residue. Youngs 303 fluid can be used if the powder is difficult to remove. Apply some pistol oil to the mop head. Insert via the open barrel end into the cartridge chamber, and with a turning action, push in and out of the chamber to remove any remaining residue or powder.
- 7 Without disassembling the concussion head, clean the sleeves and washers with a cloth and inspect for any wear.
- 8 Assuming there is no need for part replacement, wipe all steel components with an oiled cloth. Only use the recommended pistol oil (item 47) and do not over apply. Blow out any excess oil from the cartridge chamber.
- 9 Reassemble the concussion head assembly to the barrel in the reverse procedure to disassembly.
- 10 Reassemble the muzzle extension.
- 11 Lubricate the firing block pivot point, using 2 drops of pistol oil, as shown in Fig. 8.11.
- 12 Test fire with one minimum rated cartridge (refer to 'Section 5 - Effective Stunning and Cartridge Selection') to ensure tool is working correctly.

CORRECT BOLT AND MUZZLE ARRANGEMENT

NOTE - This sectional diagram shows the correct relationship between respective bolts and muzzles when assembled to the tool. If after assembly the poleaxe end of the bolt cannot be seen as shown, or protrudes further than shown, you have the wrong bolt/muzzle combination, and the tool must not be used until rectified.

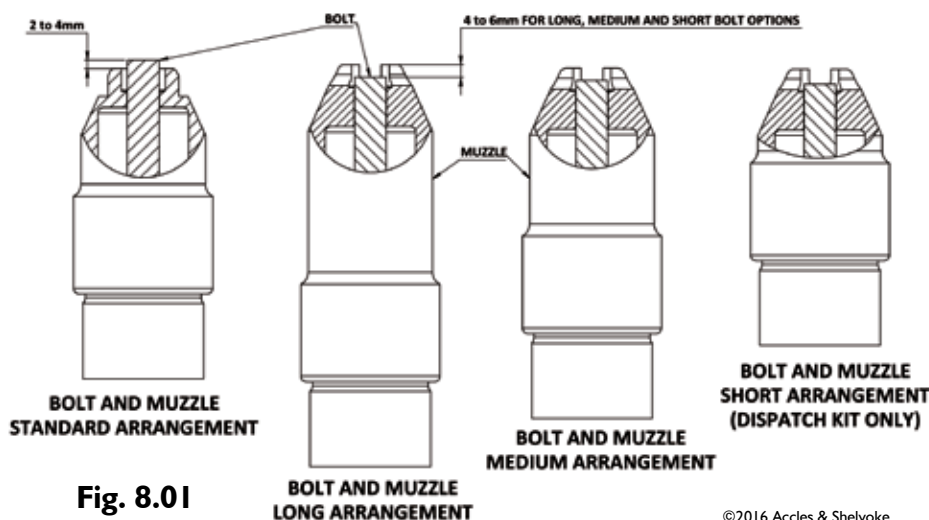

Fig. 8.01

CLEANING AND GENERAL MAINTENANCE



ALWAYS POINT THE TOOL AWAY FROM YOUR BODY AND AWAY FROM ANY OTHER PERSON IN THE VICINITY WHEN HANDLING OR OPERATING THE TOOL

CLEANING WEEKLY - CASH Special Concussion TO BE CARRIED OUT ONCE A WEEK IN ADDITION TO DAILY CLEANING

- 1 Pull back the hammer and firing block to ensure that the tool is not loaded.
- 2 Unscrew the concussion head assembly from the barrel. If it is too tight, hold the flats on the muzzle in a vice fitted with soft jaws and unscrew, using the tool handle as a lever.
- 3 Unscrew the muzzle extension from the muzzle.
- 4 With the two cone spanners - one on the piston end of the bolt and the second on the concussion head - unscrew the concussion head from the bolt. Take care not to lose the collar spring (item 40).
NOTE - Take care not to damage the bolt piston at this stage.
- 5 Withdraw the bolt/sleeves/washers from the muzzle. Wipe the inside of the barrel with the barrel/muzzle brush (item 52) to remove any soft powder and residue.
- 6 Carefully insert the breech cleaner (item 43) as shown in Fig. 8.04 and Fig. 8.05 to clean the internal breech faces and piston bore. This is best done when the barrel is still warm after use, before the powder residue solidifies. Young's 303 fluid can be used if the powder is hard and difficult to remove. Excessive powder build up will reduce the performance of the tool.
- 7 Grip the undercut cleaner (item 44) in a vice, cleaning head vertically up, as shown in Fig. 8.09.
- 8 Locate the barrel assembly over the undercut cleaner such that it enters into the barrel bore, as shown in Fig. 8.10 until it touches onto the breech face.
- 9 Apply sideways pressure to the barrel so that the undercut cleaner head enters the undercut. Maintaining the sideways pressure, rotate the barrel clockwise and anticlockwise, through 180° two or three times. Turn the barrel through 180° and repeat the process until the undercut has been thoroughly cleaned. The undercut needs to be kept clean as excessive powder build up will reduce the performance of the tool. The undercut cleaner will clean the front face of the breech block at the same time.
- 10 Assemble the chamber brush (item 60) shown in Fig. 8.06 and the chamber mop (item 61) shown in Fig. 8.07 to the brush and mop handle (item 59), screwing together hand tight. Using the brush end, insert via the open barrel end, as shown in Fig 8.08, into the cartridge chamber, and with a turning action, push in and out of the chamber to remove all powder residue. Youngs 303 fluid can be used if the powder is difficult to remove. Apply some pistol oil to the mop head. Insert via the open barrel end into the cartridge chamber, and with a turning action, push in and out of the chamber to remove any remaining residue or powder.
- 11 Check the vent hole is unblocked, clear if necessary.
- 12 Remove the washers and recuperator sleeves from the bolt. Using a wire brush, remove all powder deposits from the bolt, wiping with a lightly oiled cloth. Only use the recommended pistol oil (item 47) and do not over apply.
- 13 Examine washers and recuperator sleeves. Refer to Cleaning Daily - CASH Specials earlier in this section of this instruction manual, for guidance on checking and replacement of the washers and recuperator sleeves used with this tool.



DO NOT NEGLECT THE WASHERS OR SLEEVES. TOOL PERFORMANCE WILL BE DIMINISHED IF THESE PARTS ARE NOT KEPT IN GOOD CONDITION

- 14 Wipe all steel components with an oiled cloth. Only use the recommended pistol oil (item 47) and do not over apply. Blow out any excess oil from the cartridge chamber.
- 15 Reassemble the concussion head assembly to the barrel in the reverse order to disassembly.
- 16 Reassemble the concussion head to the bolt. Insert the collar spring (item 40) inside the threaded hole in the concussion head. We recommend the use of lockthread on the head/thread bolts to ensure the parts remain together in use. Tighten using a spanner.
- 17 Reassemble the muzzle extension.
- 18 Lubricate the firing block pivot point, using 2 drops of pistol oil, as shown in Fig. 8.11.
- 19 Test fire with one minimum rated cartridge (refer to 'Section 5 - Effective Stunning and Cartridge Selection') to ensure tool is working correctly.

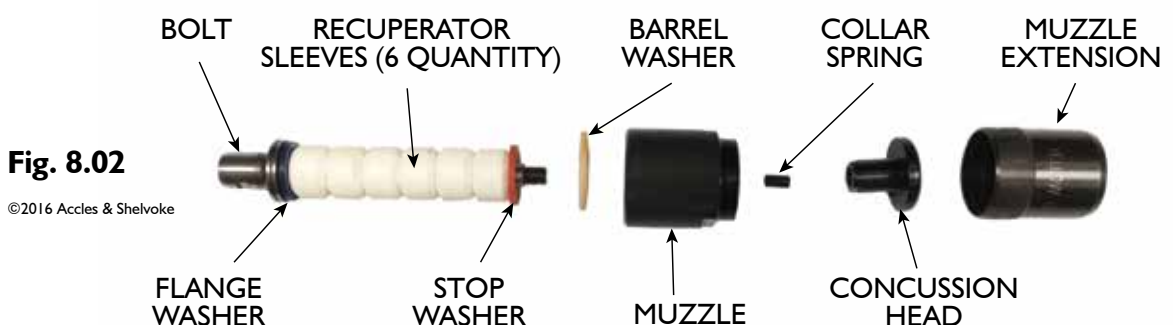

CASH® Special & CASH® Special Concussion CLEANING AND GENERAL MAINTENANCE

Fig. 8.03 Cut-away picture of a CASH Special

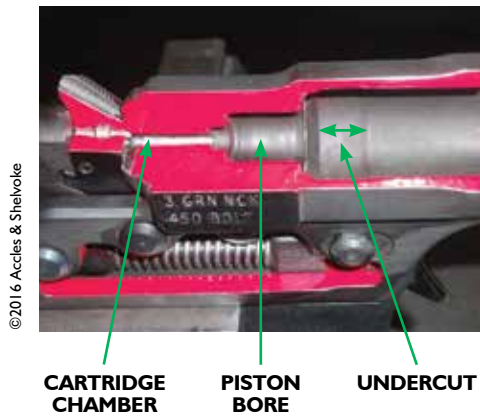

CARTRIDGE CHAMBER **PISTON BORE** **UNDERCUT**

Fig. 8.04
Breech Cleaner Assembly (item 43) inserted into a CASH Special



BARREL VENTHOLE

Fig. 8.09



Undercut cleaner (item 44) shown in a vice

Undercut cleaner head - NOTE the stepped form which sits in the undercut to remove any powder residue

Fig. 8.10



Undercut cleaner inserted inside a CASH Special showing the head located in the undercut. NOTE - the undercut is very shallow but will collect a powder build up if not cleaned properly

Fig. 8.05

Close up of Breech Cleaner Assembly with cleaning head inside piston bore



Fig. 8.06



Fig. 8.07



Fig. 8.08



Fig. 8.11



CASH® Special & CASH® Special Concussion TROUBLESHOOTING



ONLY PERSONNEL WHO HAVE BEEN AUTHORISED TO DO SO SHOULD CONDUCT ANY RECTIFICATION IDENTIFIED IN THIS TROUBLESHOOTING SECTION



ALWAYS WEAR THE CORRECT PERSONAL PROTECTIVE EQUIPMENT (PPE) WHENEVER YOU ARE WORKING WITH, CLEANING OR MAINTAINING YOUR CASH SPECIAL TOOL. ALWAYS WEAR PROTECTIVE GLASSES AND HEARING PROTECTION. THE CORRECT FOOT PROTECTION MUST BE WORN. THERE IS A RISK THAT IF THE TOOL IS DROPPED, THE BOLT MAY PENETRATE THE FOOT OF THE TOOL USER.

SYMPTOMS	CAUSES	ACTION
Cartridge misfires	Firing pin failing to make contact with cartridge Water or oil-contaminated cartridges Oil in cartridge chamber	If no indent is visible on the cartridge head, refer to corrective procedure on the next page Use a new box of cartridges Remove oil and clean the chamber
Bolt does not return fully into the muzzle	Incomplete set of recuperator sleeves and washers Worn washers and recuperator sleeves Build-up of carbon deposits on piston, breech and in chamber Bolt is bent	Check and make good, as necessary Check and replace as necessary Check and remove by cleaning as instructed in 'Section 8 - Cleaning and General Maintenance' Replace immediately
Stunner fires, but there is insufficient power to stun the animal (refer to 'Section 5 - Effective Stunning and Cartridge Selection', in this manual, for the physical signs of an effective stun)	Corrosion inside barrel Incorrect strength of cartridge being used Incorrect positioning of stunner on animal Bolt not returning fully to the breech after each shot	Check and remove if present Check type of cartridge against product code of stunner and animals being stunned by referring to 'Section 5' in this manual Check correct stunning position for type of animal being stunned by referring to 'Section 5' in this manual Check for carbon deposits on bolt, breech or in chamber and remove by cleaning as instructed in 'Section 8' of this manual Check recuperator sleeves, washers and collars for wear and replace as necessary Check number of washers, recuperator sleeves and collars, make good as necessary
Bolt sticks in animal's head	Bolt is bent Excessive build up of dirt in tool Recuperator sleeves excessively worn or missing Cutting edge of bolt narrower than shaft due to incorrect sharpening	Replace immediately Conduct cleaning as instructed in 'Section 8 - Cleaning and General Maintenance' of this manual Check and replace as necessary Replace bolt and sharpen by grinding the inside diameter only
Cartridge stuck or difficult to extract	Split cartridge or damaged cartridge chamber Cartridge chamber not clean	Return tool to maintenance department for removal and repair Refer to corrective procedure on next page Refer to 'Section 8 - Cleaning and General Maintenance' for chamber cleaning instructions
Unusually loud noise when fired	Split cartridge	Check for damaged cartridge chamber / breech, return to manufacturer for repair Check that the correct cartridge is being used





ALWAYS POINT THE TOOL AWAY FROM YOUR BODY AND AWAY FROM ANY OTHER PERSON IN THE VICINITY WHEN HANDLING OR OPERATING THE TOOL

SAFE MISFIRE REMOVAL

If the cartridge does not fire, follow the procedure below

- 1 Holding the tool with the muzzle pointing away from you or any other person, do nothing and wait for at least 30 seconds before continuing
- 2 Pull back the hammer and firing block to extract the cartridge
- 3 Observe if the cartridge is wet, oily or dirty
- 4 Look at the cartridge head - if it has been struck, drop the cartridge into a water-filled metal container to make safe
- 5 If there is no indent, follow the corrective procedure below
- 6 Clean the cartridge chamber with the chamber brush and mop as detailed in Section 8 of this instruction manual before testing with a new cartridge
- 7 If the tool misfires a second time, remove it from the work area as it requires further investigative work and servicing

MISFIRE - CORRECTIVE ACTION WHEN THE FIRING PIN DOES NOT STRIKE THE HEAD

If no indent is visible on the cartridge head, and referring to Section 10 – Servicing, in this instruction manual, strip down firing block assembly and check the condition and operation of parts

- ▶ Worn or damaged firing pin - replace pin (item 32)
- ▶ Weak or broken sear rod spring - replace sear rod spring (item 19)
- ▶ Worn or damaged firing block - replace firing block assembly (item 10)
- ▶ Worn or damaged cartridge chamber - tool has surpassed its expected usage - we recommend the purchase of a new stunning tool
- ▶ Test the tool after every corrective action to ensure the tool is working correctly before putting back into operation

TRAPPED OR STUCK CARTRIDGE REMOVAL

To remove a cartridge that is stuck and will not eject via the extractor

- 1 Unscrew and remove the muzzle from the tool
- 2 Remove the washers, sleeves and bolt
- 3 Cock the hammer and firing block so the cartridge can be seen
- 4 Grip the barrel in a soft jawed vice
- 5 Using the push rod supplied with the tool (item 45), insert into the barrel and gently push out the cartridge through the cartridge chamber
- 6 Reassemble using reverse procedure to above
- 7 Clean the cartridge chamber with the chamber brush and mop as detailed in Section 8 of this instruction manual before testing with a new cartridge
- 8 If the tool misfires a second time, remove it from the work area as it requires further investigative work and servicing

CASH SPECIAL MUZZLE AND BOLT IDENTIFICATION

The diagram below, Fig. 9.01, details the four different muzzle and bolt arrangements, with the associated part numbers for each.

In conjunction with Fig. 8.01, in Section 8, this should be used as a means of ensuring you reassemble the correct muzzle and bolt arrangement following any cleaning, general maintenance, or servicing of your CASH Special tool.

Fig. 9.01

©2016 Accles & Shelvoke

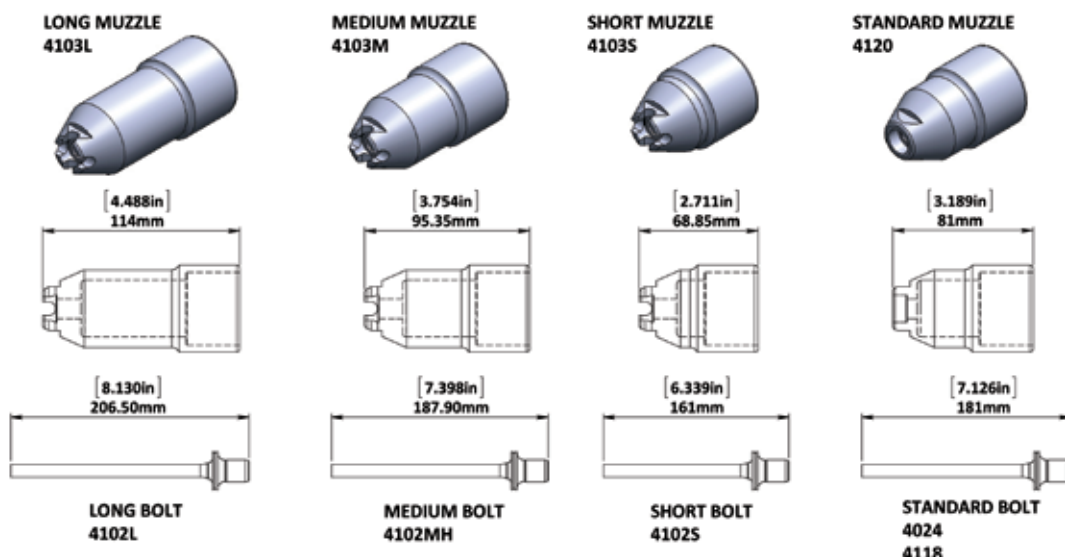

NOTE
Knurls, threads and engraving details omitted from images for clarity; The images are not to scale.

CASH® Special & CASH® Special Concussion SERVICING



DO NOT ATTEMPT TO USE THIS STUNNING TOOL UNTIL YOU HAVE READ AND UNDERSTOOD THESE INSTRUCTIONS.



ONLY PERSONNEL WHO HAVE BEEN AUTHORISED TO DO SO SHOULD CONDUCT ANY RECTIFICATION IDENTIFIED IN THIS TROUBLESHOOTING SECTION



ALWAYS WEAR THE CORRECT PERSONAL PROTECTIVE EQUIPMENT (PPE) WHENEVER YOU ARE WORKING WITH, CLEANING OR MAINTAINING YOUR CASH SPECIAL TOOL. ALWAYS WEAR PROTECTIVE GLASSES AND HEARING PROTECTION. THE CORRECT FOOT PROTECTION MUST BE WORN. THERE IS A RISK THAT IF THE TOOL IS DROPPED, THE BOLT MAY PENETRATE THE FOOT OF THE TOOL USER.



ALWAYS POINT THE TOOL AWAY FROM YOUR BODY AND AWAY FROM ANY OTHER PERSON IN THE VICINITY WHEN HANDLING OR OPERATING THE TOOL

ONLY EVER USE GENUINE ACCLES & SHELVOKE REPLACEMENT PARTS. NOT USING GENUINE PARTS MAY LEAD TO PREMATURE COMPONENT AND TOOL FAILURE, WHICH COULD ENDANGER THE OPERATOR AND THOSE IN THE IMMEDIATE VICINITY. IT WILL ALSO INVALIDATE OUR ORIGINAL EQUIPMENT WARRANTY.

ACCLES & SHELVOKE WILL ACCEPT NO LIABILITY IF ANY COMPONENTS OTHER THAN THOSE SUPPLIED BY ACCLES & SHELVOKE ARE USED WITH OUR ORIGINAL EQUIPMENT. THE RESULTANT LIABILITY WILL BE WITH THE END USER OR THE DISTRIBUTOR WHO SUPPLIED THE UNAPPROVED REPLACEMENT PARTS.

Accles & Shelvoke provide a comprehensive service and repair facility where customers can have their CASH stunner serviced by our highly experienced and trained engineers. This service is generally open to UK customers. Overseas customers are advised to contact their local distributor.

- ▶ A quotation will be provided on inspection of the return of the tool, itemising service charges and replacement parts required.
- ▶ The service involves the tool being stripped, cleaned and reassembled with the replacement parts quoted to return the tool back to good working order.

Customers are advised to contact Accles & Shelvoke direct on +44(0)121 313 3564 to make arrangements to return the tool for service and repair.

This section of the instruction manual is for servicing and parts replacement over and above the 'Cleaning and General Maintenance' recommendations.

Note - item numbers quoted in this section refer to the parts indicated by that item number in the spares diagram and spares list in Section 11 of this manual.

Section	Details	Page
10.1	How to fit a new firing pin (item 32)	27
10.2	Replacement of firing block assembly (item 10) and hammer (item 21)	28
10.3	When to replace the sear rod spring (item 19)	29
10.4	Replacing a sear rod end pin (item 22)	29
10.5	Fitting a new extractor (item 12)	30
10.6	Locking plate assembly (item 29)	31
10.7	Handle barrel bolt, firing block pivot, hammer pivot (item 14, 24 & 25) care note	31
10.8	Final checking of tool before being re-issued for stunning	31
10.9	Recommendations for recording tool maintenance activities	31

10.1 - How to fit new firing pin (item 32), part number 4167 see figures 10.01 and 10.02

- 1 Hold firing block vertically in smooth-jawed vice.
- 2 With suitable 3/32" (2.5mm diameter) hand pin punch, drive out the firing pin rivet (item 33) from the countersunk end of hole.
- 3 Reposition firing block horizontally in vice with firing pin point uppermost i.e. pawl is underneath. With a small diameter hand pin punch inserted in the firing pin hole drive out the broken firing pin and back bush (item 34).
- 4 Remove firing block from vice and examine firing pin seating for damage or burrs and remove if necessary.

Fig. 10.01

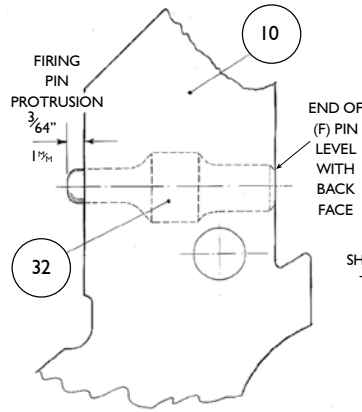

©2016 Accles & Shelvoke

Fig. 10.02

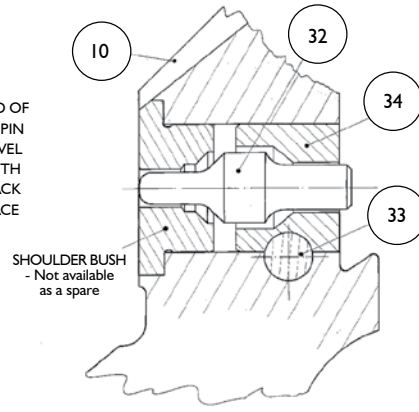

©2016 Accles & Shelvoke

- 5 Insert new firing pin and push it in as far as it will go. It should fit snugly on its seating.
- 6 Hold in position and check that the protrusion of the domed point of firing pin is 3/64" (1mm) as shown in Fig. 10.01.
- 7 If the protrusion is greater than 3/64" (1 mm), carefully reduce the domed end with a smooth file and emery cloth. If the firing pin end is filed pointed or square, it will affect product performance.
- 8 Replace the firing block in vice with the domed end of firing pin downwards. Replace the back bush, taking care to line up the rivet groove with the rivet hole in the firing block. With a suitable punch, drive the back bush exactly level with the face of the firing block.
Note - if driven in too far it will displace the front bush and cause problems with the hammer/firing block interlock.
- 9 Remove from vice and re-drill through the rivet hole to clear any burrs (use a 1/8" or 3.2 mm drill).
- 10 Insert the countersunk end of the new rivet into the rivet hole and tap home until the ends are level with the sides of the firing block. Then check the firing pin protrusion again and ensure that the pin moves freely.

In refitting it is very important that the front and back bushes are exactly level with the faces of the firing block (as shown in Fig. 10.02). If they are not, problems can occur with the hammer/firing block interlock.

10.2 - REPLACEMENT OF FIRING BLOCK ASSEMBLY 4159 (item number 10 below in spares diagram) AND HAMMER 4010/4152 (item number 21 below in spares diagram)

When replacing a firing block assembly maintaining the correct fit at the 'interlock' is vital.

Figures 10.03 and 10.04 show the interlock. It should ideally be a light fit but on no account more than .003"/.004" or .076/.102 mm clearance. Note that the two interlock faces are not flat surfaces but precise and identical circular arcs struck from the hammer and pivot centre.

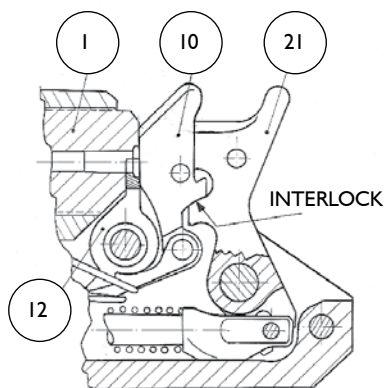

Fig. 10.03

©2016 Accles & Shelvoke

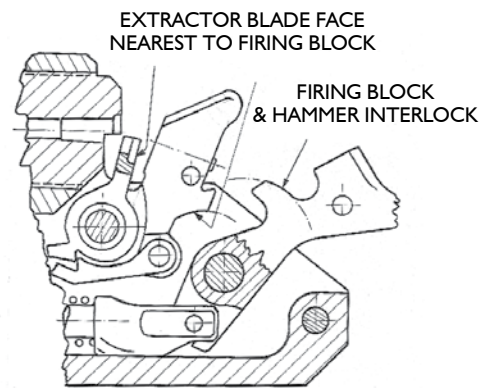

Fig. 10.04

©2016 Accles & Shelvoke

FITTING PROCEDURE

- 1 Assemble firing block (item 10) to stunner without extractor (item 12) in position.
- 2 Check interlock fit - this should be a close fit, shown in Fig. 10.03.
- 3 If adjustment is required use a smooth file on the hammer (item 21) interlock face until the correct fit is obtained. Take care to retain correct circular arc on face of interlock.
- 4 Re-assemble firing block with extractor mounted in place.
- 5 If the interlock is now tight carefully reduce the thickness of the extractor blade by smoothly filing the face nearest to firing block.
- 6 On no account must any adjustment at all be made to the new firing block; adjust the hammer first and then if necessary the extractor.

10.3 - WHEN TO REPLACE THE SEAR ROD SPRING (item 19)

SEAR ROD AND SPRING IMAGES

**STANDARD SEAR ROD (part no. 4154)
AND SPRING (part no. 4150)**



Fig. 10.05

©2016 Accles & Shelvoke

**HEAVY DUTY SEAR ROD (part no. 4018)
AND SPRING (part no. 4012)**



Fig. 10.06

©2016 Accles & Shelvoke

SPRING FREE LENGTH CHECK

**STANDARD SPRING (part no. 4150) measures
60mm (2.36") when new and unused as shown**

**Replace the STANDARD SPRING (part no. 4150)
when it measures 55mm (2.16") or less**

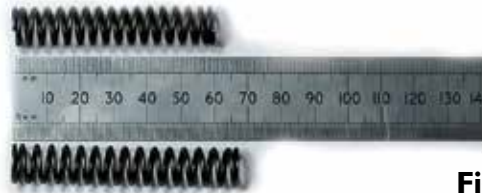

Fig. 10.07

©2016 Accles & Shelvoke

**HEAVY DUTY SPRING (part no. 4012) measures
67.5mm (2.66") when new and unused as shown**

**Replace the HEAVY DUTY SPRING (part no. 4012)
when it measures 62mm (2.44") or less**

NOTE

- ▶ Check latched end of sear rod and replace if damaged or bent

**10.4 - REPLACING BROKEN SEAR-ROD
END PIN 4153 / 4016
(Item number 22 on spares diagram)**

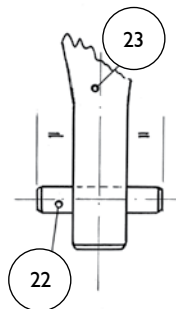

Fig. 10.08

©2016 Accles & Shelvoke

- 1 Remove sear-rod and spring from stunner and with a suitable pin punch tap out the broken portion of the sear-rod end pin if any part remains in the sear-rod.
- 2 Examine the hole and if it is badly 'bell-mouthed' (enlarged at the ends) fit a new sear-rod.
- 3 If the hole is not 'bell-mouthed' check that it is still a sliding fit for the new sear-rod end pin.
- 4 Insert the small end of the end pin in the hole, and tap in until the sear-rod is exactly equidistant between the two ends of the sear-rod end pin (Fig. 10.08).
- 5 To ensure that the sear-rod (item 23) is exactly central on the sear-rod end pin, using a hard flat surface to work on remove the handle barreled bolt nut and tap the sear-rod end pin through the nut until it hits the face of the supporting surface.

NOTE - It is important that the sear-rod end pin (item 22) is exactly central to avoid assembly difficulties later

10.5 - FITTING NEW EXTRACTOR 4141 / 4143 (item number 12 on spares diagram)

Extractors supplied for spares are fitted to a new stunner before dispatch and although all stunners are manufactured to very high tolerances it is possible, particularly in an old stunner where wear has taken place, that the extractor will need to be fitted to the stunner.

- 1 Attach the extractor to the firing block (Item 10 in spares diagram). Check that the tooth of the pawl fits the working face on the extractor (see Fig. 10.09). If necessary file this face on the extractor with a smooth file to achieve the necessary fit. If possible the tooth of the pawl should be of such a fit that it requires a slight push to engage with the working face on the extractor.
- 2 The extractor (still attached to the firing block) should be attached to the barrel. If the top face of the extractor (see Fig. 10.09) interferes with the cut out in the breech block it will be necessary to file this face of the extractor so that it just clears, allowing the 'blade' face of the extractor to seat. It is important that only the minimum amount of material is filed from this top face with a smooth file.
- 3 The hammer should now be attached to the stunner and the interlock checked as outlined under 'Replacement of firing block' where it may be necessary to file the front blade face of the extractor.

Fig. 10.09 ©2016 Accles & Shelvocke

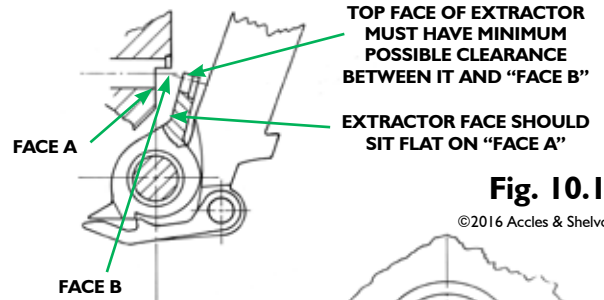

Fig. 10.10

©2016 Accles & Shelvocke

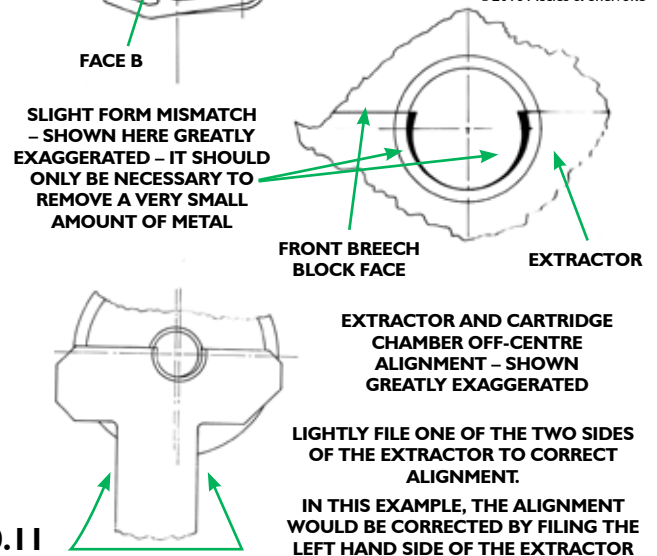

Fig. 10.11

©2016 Accles & Shelvocke

- 4 The alignment and form match of the chamber portion of the extractor should be checked by inserting a cartridge into the chamber when the extractor is attached to the firing block. The cartridge should be freely pushed into the chamber.
 - (a) If the chamber portion is central to the complete form in the breech block (see Fig. 10.10) but there is a mismatch of the form, then using a smooth round file gently remove material until the cartridge will fit.
 - (b) If the chamber portion is not central to the complete form of the chamber and breech block (see Fig. 10.11), even when any side clearance has been taken up by insertion of the cartridge, lightly file one of the two sides of the extractor boss to correct the alignment.
- 5 The stunner should now be test fired (see 'Final check of tool following maintenance').
Note: if the extraction of a spent case is tight then:
 - (a) The case must be examined for any obvious swellings or depressions around the extractor. 4 (a) or (b) should be repeated until extraction is eased.
 - (b) If there are no obvious marks on the spent case but it is difficult to extract then the fit of the pawl tooth should be eased.

It should only be necessary to remove a very small amount of material from the extractor when fitting it. Any rough filing or excessive removal of material could cause poor extraction or burst cases.

10.6 - LOCKING PLATE ASSEMBLY 4164 (item number 29 on spares diagram)

If subjected to continuous use the locking plate assembly will undergo a degree of wear and tear and become loose. Once loose it can be re-tightened by careful use of a centre punch on the rivet and by 'bowing' the top plate to restore as much tension as necessary to secure tightly. However, we recommend replacement with a completely new assembly.

10.7 - HANDLE BARREL BOLT 4147 (item number 15 on spares diagram) FIRING BLOCK PIVOT (item number 24 on spares diagram) HAMMER PIVOT (item number 25 on spares diagram)

CARE NOTE

Do not try to remove any threaded bolts or pivots by hitting the threaded ends with a hammer, as this could damage the screw threads. Instead use a soft (brass or aluminium) drift or pin between the thread and the hammer.

REPLACEMENT OF HAMMER 4152 / 4010 (item number 21 on spares diagram)

Attach hammer to barrel. See 'Replacement of firing block - section 10.2 - for details of correct interlock fit. If clearance exceeds the maximum recommended there is excessive wear on the firing block and a new part is required.

10.8 - FINAL CHECK OF TOOL FOLLOWING MAINTENANCE AND BEFORE RE-ISSUING FOR USE

Before issuing a repaired stunner always dis-assemble, check over, re-assemble and test with three shots into a thick pad of paper, then strip, thoroughly clean and oil the stunner. Finally re-assemble making sure that any paper in the pole-axe end has been removed. When fitting the bolt make sure that no dirt or foreign matter adheres to the bolt or gets into the stunner barrel, as it may work up between the bolt piston and barrel wall, or between the bolt stem and muzzle bore potentially causing extensive pick-up or scoring to the barrel wall, which could diminish the performance of the tool.

10.9 - MAINTENANCE AND CLEANING RECORD

It is a requirement of EU COUNCIL REGULATION (EC) No 1099/2009 - On the protection of animals at the time of killing, that all stunning equipment is maintained in accordance with the manufacturers' instructions and that a log detailing the maintenance is recorded and available for external auditing purposes.

We recommend you create a maintenance and cleaning record for each individual stunning tool containing as a minimum the following information:

- ▶ Stunner product code and description
- ▶ Serial number
- ▶ Service start date (date tool was first used)
- ▶ Cleaning dates - both daily and weekly (in accordance with the cleaning stated in this instruction manual)
- ▶ Part replacement details - part number and description - date replacement/maintenance took place
- ▶ Stun Check record - Univeral Stun Check unit serial number, date checked, cartridge colour used, pass or fail
- ▶ Shots fired - total number of shots fired with the tool on a daily or weekly basis
- ▶ Name and position of person conducting the cleaning or maintenance on any given day

ONLY EVER USE GENUINE ACCLES & SHELVOKE REPLACEMENT PARTS. NOT USING GENUINE PARTS MAY LEAD TO PREMATURE COMPONENT AND TOOL FAILURE, WHICH COULD ENDANGER THE OPERATOR AND THOSE IN THE IMMEDIATE VICINITY. IT WILL ALSO INVALIDATE OUR ORIGINAL EQUIPMENT WARRANTY.

ACCLES & SHELVOKE WILL ACCEPT NO LIABILITY IF ANY COMPONENTS OTHER THAN THOSE SUPPLIED BY ACCLES & SHELVOKE ARE USED WITH OUR ORIGINAL EQUIPMENT. THE RESULTANT LIABILITY WILL BE WITH THE END USER OR THE DISTRIBUTOR WHO SUPPLIED THE UNAPPROVED REPLACEMENT PARTS.

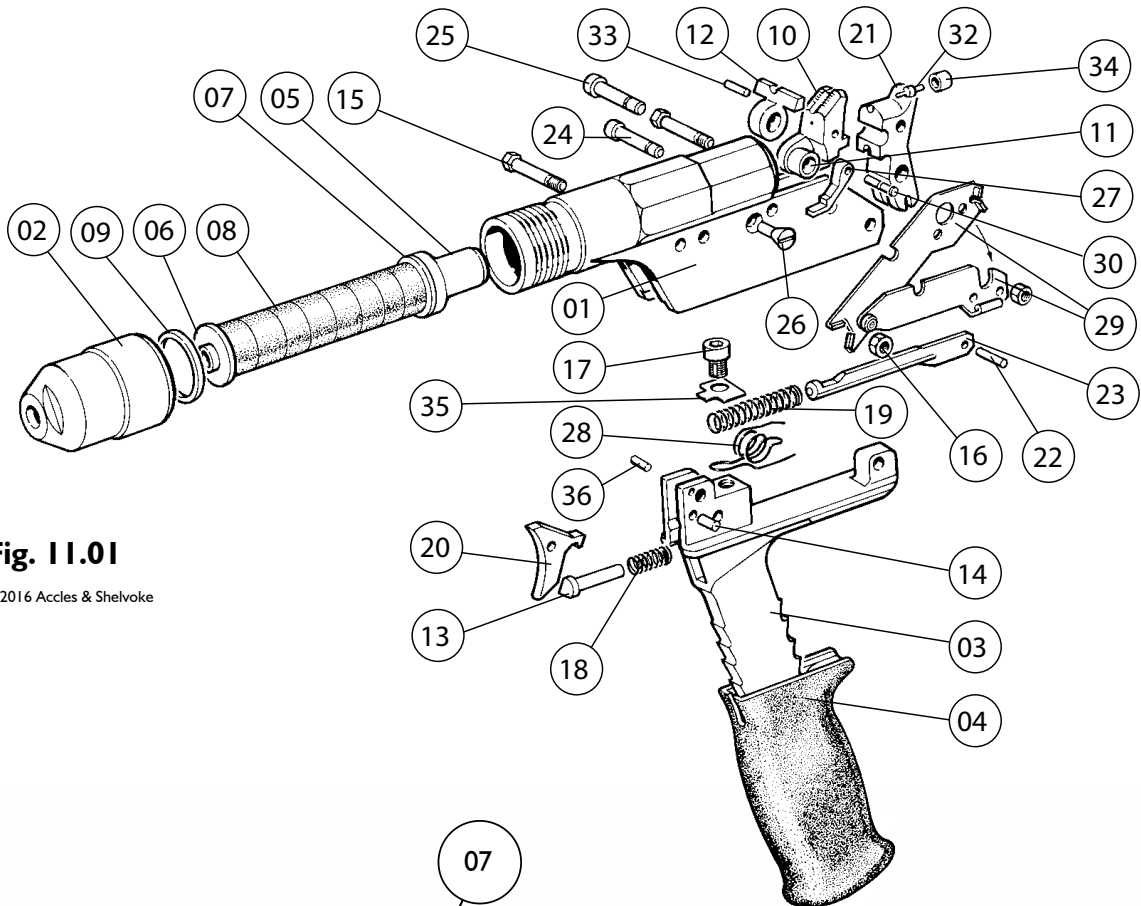

Fig. 11.01

©2016 Accles & Shelvoke



Fig. 11.02

©2016 Accles & Shelvoke

**CONCUSSION HEAD ASSEMBLY
 FOR CONCUSSION TOOLS**

CASH® Special & CASH® Special Concussion SPARE PARTS LIST AND DIAGRAM

ONLY EVER USE GENUINE ACCLES & SHELVOKE REPLACEMENT PARTS. NOT USING GENUINE PARTS MAY LEAD TO PREMATURE COMPONENT AND TOOL FAILURE, WHICH COULD ENDANGER THE OPERATOR AND THOSE IN THE IMMEDIATE VICINITY. IT WILL ALSO INVALIDATE OUR ORIGINAL EQUIPMENT WARRANTY.

ACCLES & SHELVOKE WILL ACCEPT NO LIABILITY IF ANY COMPONENTS OTHER THAN THOSE SUPPLIED BY ACCLES & SHELVOKE ARE USED WITH OUR ORIGINAL EQUIPMENT. THE RESULTANT LIABILITY WILL BE WITH THE END USER OR THE DISTRIBUTOR WHO SUPPLIED THE UNAPPROVED REPLACEMENT PARTS.

ITEM NO.	PART DESCRIPTION	QTY PER SET	SPARE PART BY PRODUCT CODE								IF ORDERING AN ASSEMBLY FOR SPARES, INCLUDES ITEMS LISTED BELOW
			CASH Special .22 R	CASH Special .22 HD	CASH Special .25	CASH Special .25R R	CASH Special .25R HD	CASH Special .25R HL	CASH Special .22 Concussion	CASH Special .25 Concussion	
			4100R	4000	4121	4121R	4121HD	4121HL	4002	4122	
1	Barrel Assembly	1	4105R	4030	4123	4123R	4123R	4123R	4105R	4123R	Includes 12, 26
2	Muzzle	1	4120	4120	4120	4120	4103M	4103L	N/R	N/R	
3	Handle	1	4116								Includes Item 36
4	Handle Grip	1	4117								
5	Bolt	1	4118	4024	4118	4118	4102MH	4102L	N/R	N/R	
6	Stop Washer	1	5369	5369	5369	5369	4040	4040	5369	5369	
7	Flange Washer - Blue	1	5403								
8	Recuperator Sleeve	As Stated	5376 x8	5376 x8	5376 x8	5376 x8	5376 x8	5376 x9	5376 x 6	5376 x 6	
9	Barrel Washer	1	4115								
10	Firing Block Assembly	1	4139								Includes 11, 32, 33, 34
11	Firing Block Bush	1	4140								
12	Extractor	1	4141	4141	4143	4143	4143	4143	4141	4143	
13	Trigger Plunger	1	4145								
14	Trigger Axis Pin	1	4146								
15	Handle Barrel Bolt	2	4147								
16	Nut	2	4159								
17	Spring Screw	1	4148								
18	Trigger Spring	1	4149								
19	Sear Rod Spring	1	4150	4012	4150	4012	4012	4012	4150	4012	
20	Trigger	1	4151								
21	Hammer	1	4152	4010	4152	4010	4010	4010	4152	4010	
22	Sear Rod End Pin	1	4153	4016	4153	4016	4016	4016	4153	4016	
23	Sear Rod Assembly	1	4154	4018	4154	4018	4018	4018	4154	4018	Includes Item 22
24	Firing Block Pivot	1	4156								
25	Hammer Pivot	1	4157								
26	Extractor Stop Screw	1	4158								
27	Pawl	1	4160								
28	Extractor Spring	1	4161								
29	Locking Plate Assembly	1	4164								
30	Pawl Pivot	1	4165								
31	Firing Pin Assembly*	1	4166*								Includes 32,33,34
32	Firing Pin	1	4167								
33	Firing Pin Rivet	1	4168								
34	Back Bush	1	4170								
35	Lock Washer	1	4171								
36	Trigger Stop	1	4179								
37	Concussion Head Assembly #	1	N/R	N/R	N/R	N/R	N/R	N/R	4315	4310	Includes 6, 7, 8, 9, 38, 39, 40, 41, 42
38	Muzzle Extension	1	N/R	N/R	N/R	N/R	N/R	N/R	4312	4300	
39	Muzzle	1	N/R	N/R	N/R	N/R	N/R	N/R	4301	4301	
40	Collar Spring	1	N/R	N/R	N/R	N/R	N/R	N/R	5631	5631	
41	Concussion Head	1	N/R	N/R	N/R	N/R	N/R	N/R	4304	4304	
42	Bolt	1	N/R	N/R	N/R	N/R	N/R	N/R	4305	4305	

N/R - This component not used on the tool stated. * - not shown as an assembly in the exploded diagram on previous page
- cone spanners - items 49 and 50 on next page - are also included when ordering a concussion head assembly

CASH® Special & CASH® Special Concussion SPARE PARTS LIST AND DIAGRAM

ONLY EVER USE GENUINE ACCLES & SHELVOKE REPLACEMENT PARTS. NOT USING GENUINE PARTS MAY LEAD TO PREMATURE COMPONENT AND TOOL FAILURE, WHICH COULD ENDANGER THE OPERATOR AND THOSE IN THE IMMEDIATE VICINITY. IT WILL ALSO INVALIDATE OUR ORIGINAL EQUIPMENT WARRANTY.

ACCLES & SHELVOKE WILL ACCEPT NO LIABILITY IF ANY COMPONENTS OTHER THAN THOSE SUPPLIED BY ACCLES & SHELVOKE ARE USED WITH OUR ORIGINAL EQUIPMENT. THE RESULTANT LIABILITY WILL BE WITH THE END USER OR THE DISTRIBUTOR WHO SUPPLIED THE UNAPPROVED REPLACEMENT PARTS.

SPARES FOR TOOL MAINTENANCE AND CLEANING

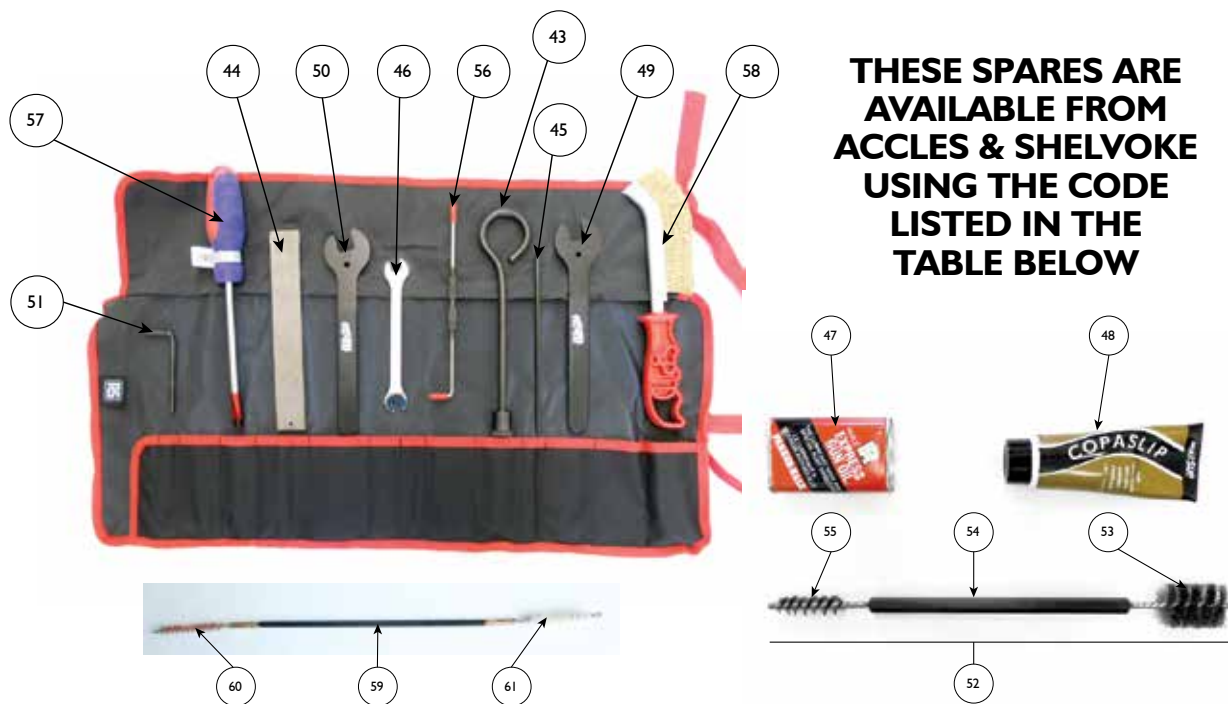

THESE SPARES ARE AVAILABLE FROM ACCLES & SHELVOKE USING THE CODE LISTED IN THE TABLE BELOW

©2016 Accles & Shelvoke

PART NO	PART DESCRIPTION	QTY PER SET	ITEM NO
4107	Breech Cleaner	1	43
4191	Undercut Cleaner	1	44
4119	Push Rod	1	45
4136	Spanner (for handle & barrel nuts)	1	46
4187	Pistol Oil *	1	47
4192	Copaslip Thread Grease *	1	48
4306	14mm Cone Spanner	1	49
4307	16mm Cone Spanner	1	50
4173	Hex Wrench (for extractor spring screw)	1	51
4121K7	Barrel/Muzzle Brush - consists of:	1	52
5645	Barrel Brush head	1	53
5647	Handle for Brush	1	54
5662	Muzzle Brush head	1	55
4121K8	Pick	1	56
4121K9	Manual Extractor	1	57
4121K10	Hand Brush	1	58
5900	Brush and Mop Handle	1	59
5901	.22" Chamber Brush - 0.22" CALIBRE ONLY	1	60
5902	.25" Chamber Brush - 0.25" CALIBRE ONLY		
5903	.22" Chamber Mop - 0.22" CALIBRE ONLY	1	61
5904	.25" Chamber Mop - 0.25" CALIBRE ONLY		
6076	Youngs 303 Fluid *	1	not shown

* Product data sheets area available upon request.

CASH® Dispatch Kit

CASH® DISPATCH KIT

- PRODUCT CODE 4121KI

The CASH Dispatch Kit consists of a set of assemblies that provide the means of creating one of four CASH Special stunning tool options. In conjunction with appropriate cartridge selection, this allows the end user to select a suitable combination of tooling and cartridge to dispatch the subject animal.

This kit is designed to offer a flexible option for in-field stunning for a variety of animals of differing sizes and weights, as part of a 2-stage dispatch process.

All components and assemblies provided in this kit are used in the CASH Special range of tools. Available in .25" calibre only.

The Dispatch Kit consists of:

- 4121K1 Heavy Duty Barrel Assembly
- 4121K2 Bolt Assembly Long
- 4121K3 Bolt Assembly Medium
- 4121K4 Bolt Assembly Short
- 4121K5 Concussion Head Assembly

NOTE - all of the assemblies above are identified with and are available as spares with the part numbers shown.

- 4107 Breech Cleaner
- 4191 Undercut Cleaner
- 4119 Push Rod
- 4136 Spanner (for handle and barrel nuts)
- 4187 Pistol Oil
- 4192 Copaslip Thread Grease
- 4306 14mm Cone Spanner
- 4307 16mm Cone Spanner
- 4173 Hex Wrench (for extractor spring screw)
- 4121K10 Hand Brush
- 4121K8 Pick
- 4121K9 Manual Extractor
- 4121K7 Barrel/Muzzle Brush
- 5900 Brush and Mop Handle
- 5902 .25" Chamber Brush
- 5904 .25" Chamber Mop

Cartridges

.25" cartridges are available in 4 strength options:

COLOUR	GRAINS	PART No.
PINK	1.25 GRAIN	4121KA
YELLOW	2 GRAIN	4121KB
BLUE	3 GRAIN	4121KC
ORANGE	3.5 GRAIN	4121KD

To assist you in deciding the appropriate cartridge, please refer to 'Section 5 - Effective Stunning & Cartridge Selection' of this instruction manual, or the Quick Reference Guide in this section of the manual (also supplied as a wipe clean sheet with your Dispatch Kit).

For safety reasons, cartridges have to be purchased and transported separately to stunner tools.



Example of a .25 CASH Dispatch Kit

©2016 Accles & Shelvoke



Example of a .25 CASH Dispatch Kit in case

©2016 Accles & Shelvoke



Example of a .25 CASH Dispatch Kit case lock

©2016 Accles & Shelvoke

Lockable Case

Your Dispatch Kit is supplied with a lockable case. We advise when not in use, the case is locked and stored in a safe place.

To set the number to the lock, please refer to the separate setting guide supplied within the kit.



ALWAYS WEAR THE CORRECT PERSONAL PROTECTIVE EQUIPMENT (PPE) WHENEVER YOU ARE WORKING WITH, CLEANING OR MAINTAINING YOUR CASH SPECIAL TOOL. ALWAYS WEAR PROTECTIVE GLASSES AND HEARING PROTECTION. THE CORRECT FOOT PROTECTION MUST BE WORN. THERE IS A RISK THAT IF THE TOOL IS DROPPED, THE BOLT MAY PENETRATE THE FOOT OF THE TOOL USER.



ALWAYS POINT THE TOOL AWAY FROM YOUR BODY AND AWAY FROM ANY OTHER PERSON IN THE VICINITY WHEN HANDLING OR OPERATING THE TOOL

The equipment in this kit enables the construction of 4 different CASH Special combinations. These combinations and a guide to helping you select the correct cartridge can be found in the CARTRIDGE QUICK REFERENCE GUIDE in this section of the manual

GENERAL SAFETY STATEMENT

- ▶ THE INTENDED USE OF THIS TOOL IS FOR THE STUNNING OF ANIMALS PRIOR TO SLAUGHTER OR DEPOPULATION
- ▶ ANYONE GRANTED THE AUTHORITY TO USE ONE THESE TOOLS TO STUN ANIMALS SHOULD HAVE READ THIS INSTRUCTION MANUAL SUCH THAT THEY ARE MADE FULLY AWARE OF THE POTENTIAL RISKS
- ▶ THIS TOOL HAS THE POTENTIAL TO CAUSE SEVERE INJURY OR FATALITY IF USED IMPROPERLY OR INAPPROPRIATELY OUTSIDE OF ITS INTENDED SCOPE OF USE

Please read and understand 'Section 6 - General Safety Precautions' as they apply to the use of this kit and any of its assembled combinations.

To ensure an effective stun, please refer to either the 'CASH Dispatch Quick Reference Guide' (also supplied loose) or 'Section 5 - Effective Stunning and Cartridge Selection' in this instruction manual.

Please refer to 'Section 7 - Safe Operating Instructions' for details of how to use this stunning tool.

The same 'Section 8 - Cleaning and General Maintenance' conditions in this manual apply to this kit as with any stunning tool.

It is a condition of Accles & Shelvoke's product liability insurance that only CASH cartridges, in CASH cartons and bearing "E" or "C" headmarks, be used in stunners manufactured by Accles & Shelvoke. It follows therefore, that no liability whatsoever can be accepted for any claim, including injury, should any other brand of cartridge be used.

Where cartridges other than these are used, Accles & Shelvoke will not accept responsibility for:



















- ▶ The safety of the operator
- ▶ The humaneness of the stun
- ▶ The correct operation of the stunning tool
- ▶ The premature failure of parts

Cartridges must be stored in cool, dry conditions. Exposure to excessive amounts of moisture may affect cartridge performance, which in turn will affect tool performance with the potential to create an ineffective stun of the animal.

When not in use, cartridges should be locked away separately from any stunning tools.

CASH® Dispatch Kit
CARTRIDGE QUICK
REFERENCE GUIDE

The information provided within this section is not categorical and is intended for guidance only. There is further information within the instruction manual supplied with this tool to ensure the welfare of the animal is maintained throughout the slaughter process.

	ANIMAL	STUNNER/CARTRIDGE COMBINATION
	Poultry	5A
	Neonates & Suckling Pigs - Up to 7kg (15lbs)	5A
	Nursery Pigs - 7kg to 18kg (15 to 40lbs)	5B
	Nursery Pigs - Up to 25kg (55lbs)	4A
	Growers, H. Growers & L. Finishers - Up to 90kg (200)	3B
	Finishers - Up to 135kg (300 lbs)	3C
	H. Finishers & Gilts	3D
	Sows & Boars	2D
	Neonate Lambs	5B
	Lambs	4A
	Sheep	3B
	Mature Sheep & Rams	3C
	Mature Sheep & Rams - with extensive horn structure	2D
	Neonate Calf	5B
	Average size Cattle	3C
	Heavy Cattle & Bulls	2D
	Average Size Horse	3D
	Large Horse	2D

NOTE - EU only - Concussion tools shall only be used on ruminants if less than 10Kg of live weight.

SELECTION CODE	TOOL COMBINATIONS	TOOL DESCRIPTION
2	412IK1 and 412IK2	.25" Cash Special, Long Bolt
3	412IK1 and 412IK3	.25" Cash Special, Medium Bolt
4	412IK1 and 412IK4	.25" Cash Special, Short Bolt
5	412IK1 and 412IK5	.25" Cash Special Concussion

SELECTION CODE	CARTRIDGE COLOUR	GRAINS	PART No.
A	PINK	1.25 GRAIN	412IKA
B	YELLOW	2 GRAIN	412IKB
C	BLUE	3 GRAIN	412IKC
D	ORANGE	3.5 GRAIN	412IKD

 **ENSURE THE SELECTED CARTRIDGE IS NO MORE POWERFUL (THE GRAIN SIZE IS NOT EXCEEDED) THAN THE MAXIMUM STATED ON THE MUZZLE OF THE TOOL BEING USED**

CASH® Dispatch Kit SPARE PARTS LIST

ONLY EVER USE GENUINE ACCLES & SHELVOKE REPLACEMENT PARTS. NOT USING GENUINE PARTS MAY LEAD TO PREMATURE COMPONENT AND TOOL FAILURE, WHICH COULD ENDANGER THE OPERATOR AND THOSE IN THE IMMEDIATE VICINITY. IT WILL ALSO INVALIDATE OUR ORIGINAL EQUIPMENT WARRANTY.

ACCLES & SHELVOKE WILL ACCEPT NO LIABILITY IF ANY COMPONENTS OTHER THAN THOSE SUPPLIED BY ACCLES & SHELVOKE ARE USED WITH OUR ORIGINAL EQUIPMENT. THE RESULTANT LIABILITY WILL BE WITH THE END USER OR THE DISTRIBUTOR WHO SUPPLIED THE UNAPPROVED REPLACEMENT PARTS.

CODE	PART DESCRIPTION	QTY	ITEM NO *
4121K1	Heavy Duty Barrel Assembly:-	1	
4123R	.25" Barrel/Breech Assembly	1	1
4116	Handle	1	3
4117	Handle Grip	1	4
4139	Firing Block Assembly	1	10
4140	Firing Block Bush	1	11
4143	Extractor	1	12
4145	Trigger Plunger	1	13
4146	Trigger Axis Pin	1	14
4147	Handle Barrel Bolt	2	15
4159	Nut	2	16
4148	Spring Screw	1	17
4149	Trigger Spring	1	18
4012	Sear Rod Spring	1	19
4151	Trigger	1	20
4010	Hammer	1	21
4016	Sear Rod End Pin	1	22
4018	Sear Rod Assembly	1	23
4156	Firing Block Pivot	1	24
4157	Hammer Pivot	1	25
4158	Extractor Stop Screw	1	26
4160	Pawl	1	27
4161	Extractor Spring	1	28
4164	Locking Plate Assembly	1	29
4165	Pawl Pivot	1	30
4166	Firing Pin Assembly	1	31
4167	Firing Pin	1	32
4168	Firing Pin Rivet	1	33
4170	Back Bush	1	34
4171	Lock Washer	1	35
4179	Trigger Stop	1	36

CODE	PART DESCRIPTION	QTY	ITEM NO *
4121K2	Bolt Assembly Long	1	
4103L	Muzzle (Long)	1	2
4102L	Bolt (Long)	1	5
4040	Stop Washer	1	6
5403	Flange Washer - Blue	1	7
5376	Recuperator Sleeve	9	8
4115	Barrel Washer	1	9

CODE	PART DESCRIPTION	QTY	ITEM NO *
4121K3	Bolt Assembly Medium	1	
4103M	Muzzle (Medium)	1	2
4102MH	Bolt (Medium)	1	5
4040	Stop Washer	1	6
5403	Flange Washer - Blue	1	7
5376	Recuperator Sleeve	8	8
4115	Barrel Washer	1	9

CODE	PART DESCRIPTION	QTY	ITEM NO *
4121K4	Bolt Assembly Short	1	
4103S	Muzzle (Short)	1	2
4102S	Bolt (Short)	1	5
4040	Stop Washer	1	6
5403	Flange Washer - Blue	1	7
5376	Recuperator Sleeve	6	8
4115	Barrel Washer	1	9

CODE	PART DESCRIPTION	QTY	ITEM NO *
4121K5	Concussion Head Assembly	1	
5369	Stop Washer	1	6
5403	Flange Washer - Blue	1	7
5376	Recuperator Sleeve	6	8
4115	Barrel Washer	1	9
4300	Muzzle Extension	1	38
4301	Muzzle	1	39
5631	Collar Spring	1	40
4304	Concussion Head	1	41
4305	Bolt	1	42
4306	14mm (Cone spanner)	1	49
4307	16mm (Cone spanner)	1	50

* Item number on Spares Diagram in section 11 of this manual.

In addition to the parts listed on this page, the spares and tool maintenance parts listed in Section 11 are available for cleaning and general maintenance purposes.

CONTACT DETAILS, WARRANTY AND RECYCLING

Contact us today to find out how Accles & Shelvoke can help your current or future stunning requirements.

For customers based in Canada and USA:-

Accles & Shelvoke, 773 Victory Highway, West Greenwich, Rhode Island 02817, USA.

Website: www.accles-shelvoke.com Email: info@accles-shelvoke.com

Telephone: (1)-800-396-9497 Fax: (1)-401-397-5031

For all other customers:-

Accles & Shelvoke Ltd, Unit 5A, Maybrook Road, Maybrook Business Park, Minworth, Sutton Coldfield, Birmingham, West Midlands, UK B76 1AL

Website: www.acclesandshelvoke.co.uk Email: info@acclesandshelvoke.co.uk

Telephone: +44 (0)121 313 3564 Fax: +44 (0)121 313 0282

WARRANTY

The Accles & Shelvoke product warranty policy is available upon request. The product warranty policy, like any other, is conditional.

Your tool has been assembled, tested and proof-stamped as a mark of its performance, quality and safety, and arrives with you in full working order.

Your CASH Special tool has been designed and developed over 100 years of experience in the meat processing industry. It has proven to be a very reliable and robust tool if cleaned and maintained in accordance with this instruction manual.

In the event of any problems, please contact your local distributor.

RECYCLING

Once any component or tool has surpassed its useful life, it needs to be disposed of in a responsible manner. Most of the materials from which the Accles & Shelvoke range of stunning tools is manufactured can be recycled.

These materials must be correctly separated before they can be recycled. To do so, disassemble the tool, and sort into the groups highlighted in the table below. Use the spares list and diagram (Section 11) to help with identification.

The disassembled and sorted items may be disposed of at an appropriate recycling facility.

ITEMS / PARTS	MAIN MATERIAL	DISPOSAL
All components itemised in the 'Spare Parts List and Diagram' except those detailed below	Steel	Ferrous Metal Recycling
4, 6, 7, 8, 9	Rubber	General Waste
Spent Cartridges	Brass	Non-ferrous Metal Recycling
Packaging - cardboard	Cardboard	Cardboard recycling
Packaging - plastic	Plastic	Plastics recycling
Other non-specified items	Various	General Waste

DECLARATION OF CONFORMITY



**accles
& SHELVOKE**[®]
Since 1913

Manufacturer name:	Accles & Shelvoke		Machinery covered by this declaration	
Full address:	Unit 5A, Maybrook Road, Maybrook Business Park, Minworth, Sutton Coldfield, Birmingham, West Midlands, UK B76 1AL		Description:	CASH Special range of captive bolt stunning tools
			Function:	For the stunning of livestock prior to slaughter or depopulation
			Product Code of stunner supplied with instruction manual	NOTE APPLY PRODUCT CODE & PRODUCT DESCRIPTION LABEL HERE
Product Description				
Full list of products declared under this Certificate Number:	4000 CASH Special .22 HD 4100R CASH Special .22R 4121 CASH Special .25 4121K CASH Dispatch Kit 4121R CASH Special .25R 4121HD CASH Special .25R HD 4121HL CASH Special .25R HL 4002 CASH Special .22 Concussion 4122 CASH Special .25 Concussion		Serial number:	NOTE APPLY SERIAL NUMBER LABEL HERE

The machinery conforms to all the requirements of the Machinery Directive 2006/42/EC

The machinery also conforms to the following Directives and UK Laws:	EU Council Regulation (EC) No 1099/2009 on the protection of animals at the time of killing; The Gun Barrel Proof Act 1978;
---	--

The following standards have been used:	EN ISO 12100:2010
--	-------------------

Notified body who carried out the EC type examination or Full Quality Assurance :	Name:		
	Address:	amtri veritas ltd, veritas house, pierce street, macclesfield sk11 6er	
	Notified body No. :	0463	Certificate No.: AVEC 3847

The technical file is compiled in accordance with part A of Annex VII of the Machinery Directive 2006/42/EC

Person authorised to compile the technical file (based in the European Community):	Name:	Steve West - Manufacturing Manager
	Address:	Refer to company address above

The relevant authorised person undertakes to transmit, in response to a reasoned request by the national authorities, relevant information on the machinery. This information will be transmitted by: e-mail

Person authorised to make this declaration:	Name:	Joe Holland
	Position in company:	General Manager
	Signature:	
	Place of declaration:	Unit 5A, Maybrook Road, Maybrook Business Park, Minworth Sutton Coldfield, Birmingham, West Midlands, UK B76 1AL
	Date of declaration:	1 st May 2017